

LLOYD TABLE COMPANY

GALAXY McMANIS STATIONARY

OPERATION & PARTS MANUAL



Lloyd Table Company
102 W. Main Street * Lisbon, IA 52253
Phone 319-455-2110 Fax 319-455-2166
Website www.lloydtable.com
Email sales@lloydtable.com
Call Toll Free 1-800-553-7297

LLOYD
TABLE COMPANY

CONTENTS

<u>OPERATIONS</u>	<u>PAGE</u>	<u>PARTS / ASSEMBLY</u>	<u>PAGE</u>
Safety and Maintenance.....	1-2	Base Frame.....	15-16
Head Rest Cushion.....	3-7	Deluxe Head Cushion.....	17
Chest Cushion.....	8-9	Deluxe Head Frame.....	18
Chest - Pelvic Extension / Retraction....	10	Chest Cushion Assembly.....	19-20
Pelvic Cushion - Flexion.....	11	I-Frame, Deluxe Head.....	21-22
Pelvic Drop & Side Bending.....	12	Ankle Rest Adjustable Height.....	23-24
Pelvic Rotation & Telescoping T-Bar....	13	Hydraulics.....	25-26
Ankle Rest & Lumbar Extension.....	14	Straight Drop Head.....	27-28
		Forward Motion Drop Head.....	29-30
		Flexion Head Cushion Assembly.....	31-32
		Flexion Head - Shuttle Assembly.....	33-34
		Flexion Head - Slide Frame.....	35-36
		Flexion Head Rotation Block.....	37-38
		Drop Chest & Lumbar.....	39-40
		Drop Chest - Full Cushion.....	41-42
		T-Pelvic Cushion Non-Rotation.....	43
		Telescoping T-Bar.....	44
		T-Drop Pelvic Non Rotation.....	45-46
		T-Drop Pelvic Rotation.....	47-48

WELCOME!!

Lloyd Table Company, a proud supporter of today's chiropractors, has established the finest line of chiropractic tables in the world. Table products unique in versatility and function, designed to meet your needs.



Concerned for a safe working and treatment environment, Lloyd Table Company asks that you follow the safety tips below.

- * Be aware of Caution and Warning labels posted throughout the table before operating any functions.
- * Everyone operating the table needs to read the manual and familiarize themselves with all its functions before operating table with patient on it.
- * The McManis pelvic operation is only to be operated by a professional practitioner, educated in the procedure of the flexion distraction and traction on the lower back and spine.
- * A patient should never be unattended, when lying on the table.
NEVER LEAVE A PATIENT ON THE TABLE UNATTENDED!

Secure the pelvic cushion into all lock positions before allowing patient on or off the table.

(See pages 12 - 17 to lock pelvic rotation, pelvic flexion, and pelvic side bending)

- * The patient should be positioned at or near the center of the table with arms on the armrest cushions.
- * There should be no more than one operator at the controls.
- * The pressure gauge reading should never exceed 800 PSI or drop below 300 PSI
- * Check the tension on all drops before adjusting the patient. (See Page 9)



MAINTENANCE

The following steps should be performed on a regular basis to maintain your Lloyd table in a smooth operating condition and to assure its long life and top quality appearance.

- * An initial inspection and periodic future inspections should be made to insure that nuts and bolts have not loosened in shipping or during daily operations.
- * Your Lloyd table should be lubricated every six months. Parts to be lubricated are all frame pivot points, and metal to metal sliding mechanisms.
(DO NOT LUBRICATE FRICTION LOCKS)
- * The cushions should be cleaned daily with a mild soap & warm water solution to remove body oils. Rinsed & dried.
DO NOT USE VINYL CLEANERS TO CLEAN CUSHIONS!!
- * Chrome parts should be cleaned on a weekly basis for appearance.
- * The hydraulic fluid recommended for the pump, is a lubriplate HO1 or hydraulic jack oil, and should be checked on a yearly basis.
- * Perform periodic inspections for oil leaks or drips.
- * The fluid level in the pump's reservoir tank should measure 1-3/4 of an inch from full. This measurement is taken when the pelvic cushion is in the down position, the pressure gauge is released back to zero, table is in lowest elevated position and fully shortened or retracted.

The following sections provide explanations on the operation of your Lloyd table. All references to right and left, will be in relationship to your view, as you face table from the head end. All references to the front will refer to the head end of the table. Those to the rear will refer to the foot end.

Head Cushion

The head cushion is designed to provide a multitude of positions & operations through our standard Deluxe Headpiece and optional Total Dimension Flexion™ Headpieces.

Standard Deluxe Headpiece

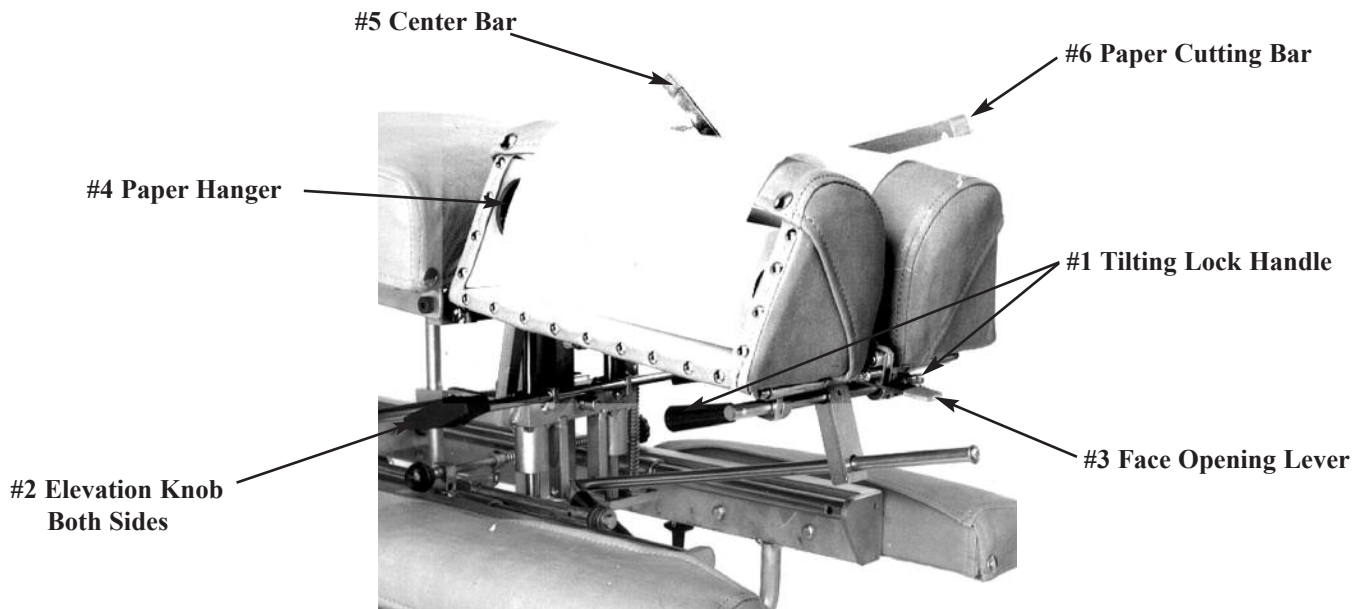

To Raise the tilting feature on the Deluxe Headpiece:

1. Lift on the bottom front edges of the cushion
2. Release at the desired height, the cushion will automatically lock into position.



To Lower the tilting feature on the Deluxe Headpiece:

1. Support the front corner edge of the cushion.
2. Lift the Locking Handle (No. 1) to release.
3. Gently lower the cushion to the desired height.
4. Release the lock handle first and then the cushion to lock.



WARNING: TO AVOID INJURIES WHEN RAISING OR LOWERING HEAD CUSHIONS, BE SURE TO HAVE A PROPER HOLD ON THE CUSHION BEFORE RELEASING THE ELEVATING HANDLE (NO. 2).

Standard - Deluxe Head



To Elevate the Head Cushion

1. The head cushion is assisted by a gas shock in raising the cushion. With a hand supporting the head cushion, turn the Elevation Knob (No. 2) on either side of the table upward to unlock. When the desired height is determined simply release the Elevation Knob (No. 2) to lock.

To Lower the Head Cushion

1. Turn the Elevation Knob upward to unlock. While unlocked push down on the cushion to lower. When the desired height is determined simply rotate the Elevation Knob (No. 2) down to lock.

Face Opening Adjustment

1. The Head Cushion's face opening can be opened or closed to adjust for comfort with the Face Opening Lever (No. 3). By Pushing slightly down on the Face Opening Lever, slide side to side adjusting the face opening. The Face Opening Lever must be released in one of eight positions to lock the cushions in place.

Paper Roll

The paper roll mounts conveniently inside the right-hand cushion.

Replacing the Paper Roll

1. Remove the paper hanger tension rod (No. 4) by compressing ends of the rod horizontally. This will allow you to slide one end out, to remove the paper roll tube.
2. Slide a new paper roll on the tension rod so that it rolls off the bottom side. Compress the rod ends horizontally and set inside the head cushion.
3. Swing the Center Bar (No. 5, Page 3) and Outside Cutting Bar (No. 6, Page 3) up. Route paper over the cushions and down between the two outside cutting bars. Return both bars to their original position.
4. Trim the paper by supporting the paper cutting bar with one hand and pulling the paper up along the bar's edge.

Deluxe Head with Drops

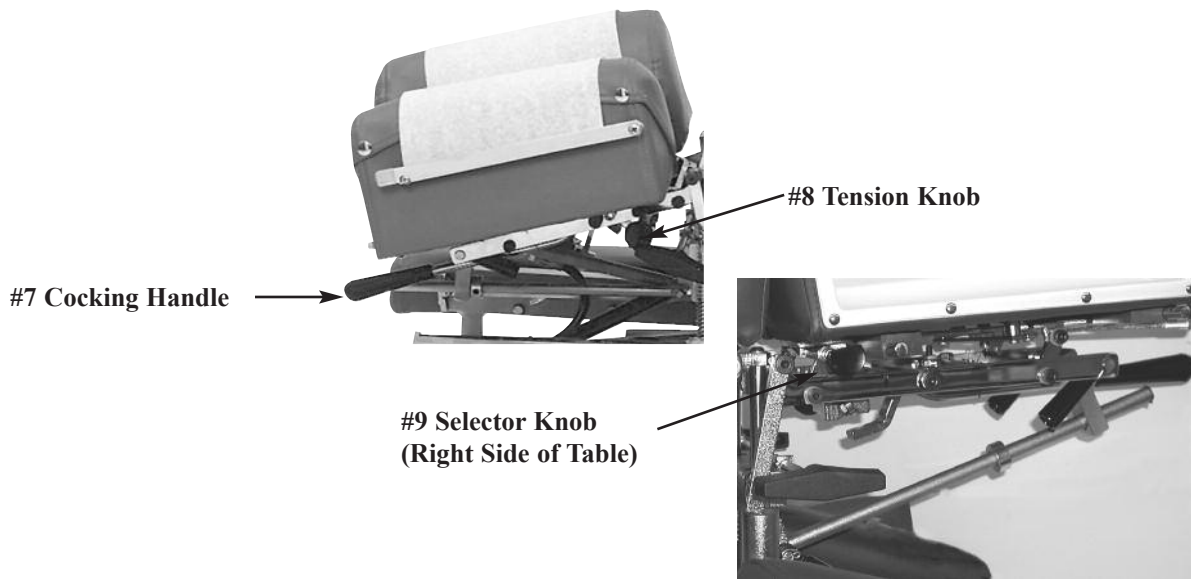

Operating the Straight / Toggle Drop:

CAUTION: THE DROP CUSHION TENSION SHOULD BE CHECKED AND TESTED BEFORE ADJUSTING A PATIENT.

NOTE - DROP SHOULD BE IN DOWN / DEACTIVATED POSITION BEFORE MOVING SELECTOR KNOB (NO. 9) IN OR OUT.

1. To engage the Straight / Toggle Drop head, pull the selector knob (No. 9) out about half an inch.
2. Push down on the Cocking Handle (No. 7) until the head cushion is cocked into its top position.
3. Once cocked, test the drop by pushing down on the cushion. If the cushion drops too easily or too hard, adjust the tension with the Tension Knob (No. 8).

Operating The Tension Knob:

1. The tension is adjusted by turning the tension knob (No. 8) in a clockwise and counterclockwise direction.
 - A. Clockwise - Increases tension
 - B. Counterclockwise - Decreases tension

Operating the Forward Motion Drop:

CAUTION: THE DROP CUSHION TENSION SHOULD BE CHECKED AND TESTED BEFORE ADJUSTING A PATIENT.

NOTE - DROP SHOULD BE IN DOWN / DEACTIVATED POSITION BEFORE MOVING SELECTOR KNOB (NO. 9) IN OR OUT.

1. The Selector Knob (No. 9) is to be pushed in, to engage the forward motion drop.
2. Push down on the Cocking Handle (No. 7) to raise into its cocked position.
3. Once cocked, test the drop by pushing down on the cushion, and adjust the tension (see above Operating the Tension Knob section).

Optional - Total Dimension Flexion Head™

Right Side

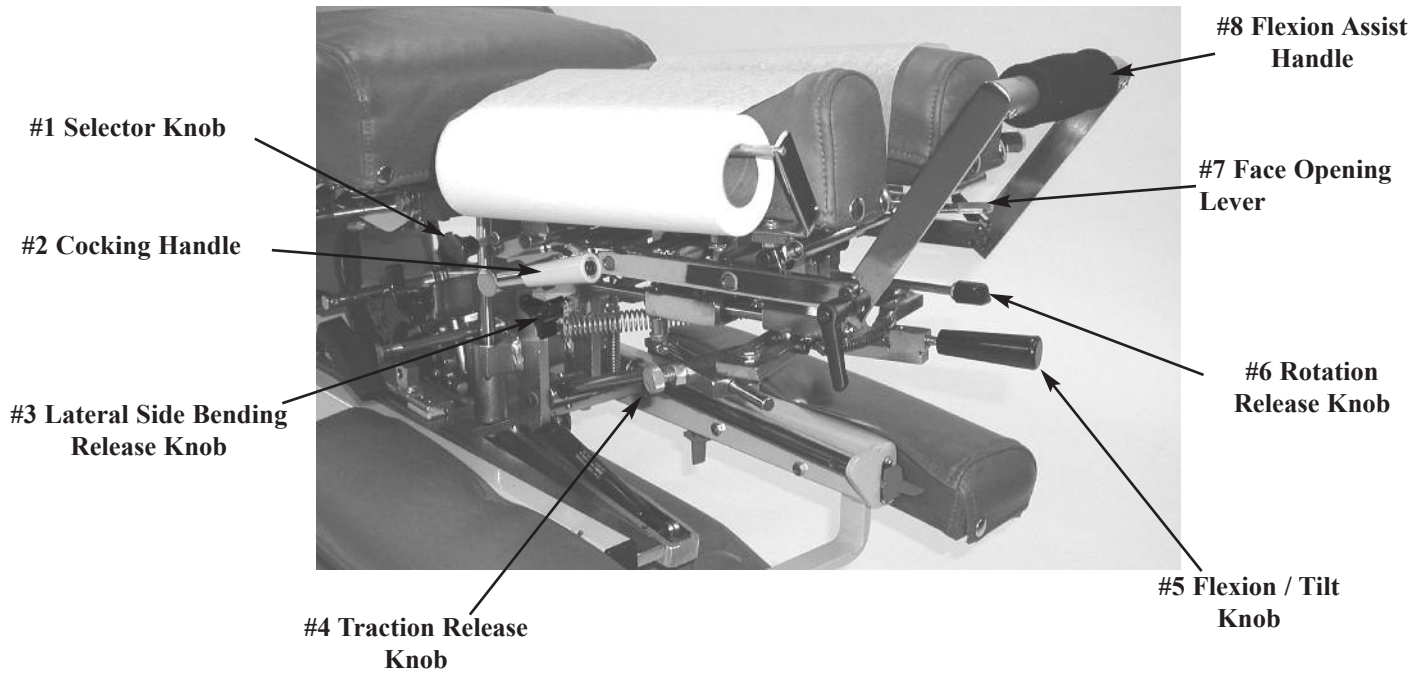

Forward & Straight / Toggle Drop Operation Instructions



CAUTION: THE DROP CUSHION TENSION SHOULD BE CHECKED AND TESTED BEFORE ADJUSTING A PATIENT.

NOTE - DROP SHOULD BE IN DOWN / DEACTIVATED POSITION BEFORE MOVING SELECTOR KNOB (NO. 9) IN OR OUT.

1. To engage the Straight / Toggle Drop head, pull the selector knob (No. 1) out about half an inch.
2. Push down on the Cocking Handle (No. 2) until the head cushion is cocked into its top position.
3. Once cocked, test the drop by pushing down on the cushion. If the cushion drops too easily or too hard, adjust the tension with the Tension Knob (No. 9).

Operating The Tension Knob:

1. The tension is adjusted by turning the tension knob (No. 9) in a clockwise and counterclockwise direction.
 - A. Clockwise - Increases tension
 - B. Counterclockwise - Decreases tension

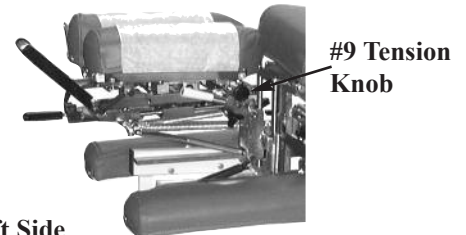

Operating the Forward Motion Drop:

Left Side

1. The Selector Knob (No. 1) is to be pushed in, to engage the forward motion drop.
2. Push down on the Cocking Handle (No. 2) to raise the drop cushion to its cocked position.
3. Once cocked, test the drop by pushing down on the cushion. If the cushion drops too easily or too hard, adjust the tension with the Tension Knob (No. 9).

Total Dimension Flexion Head™



WARNING: THE FOLLOWING CERVICAL OPERATIONS ARE ONLY TO BE OPERATED BY A PROFESSIONAL PRACTITIONER, EDUCATED IN THE PROCEDURE OF FLEXION-DISTRACTION AND TRACTION, ON THE SPINE.



Lateral Side Bending

1. To unlock the Lateral Side Bending Feature rotate the Lateral Side Bending Release Knob (No. 3) clockwise (from left side of table).
2. Turn the Lateral Side Bending Release Knob (No. 3) counterclockwise to lock headpiece in desired position (from left side of table).



CAUTION: MAKE SURE THE HEADPIECE IS LOCKED BEFORE ALLOWING A PATIENT ON OR OFF THE TABLE.

Manual Traction

1. To unlock the manual traction feature simply pull and twist the Traction Release Knob (No. 4) 1/4 of a turn clockwise or counterclockwise.
2. When unlocked the headpiece will glide forward and backward.
3. To lock the manual traction twist the Traction Release Knob (No. 4) 1/4 turn counterclockwise or clockwise.

Manual Flexion Distraction

1. To unlock the manual flexion distraction locate the Flexion / Tilt Knob (No. 5) pull forward and twist 1/4 turn counterclockwise.
2. Gently apply pressure down using the Flexion Assist Handle (No. 8).
3. To lock the manual flexion distraction twist the Flexion / Tilt Knob (No. 5) 1/4 turn clockwise and release to engage lock.

Tilting Feature

1. To unlock the Tilting feature locate the Flexion / Tilt Knob (No. 5) while supporting the head cushion pull forward and twist counterclockwise.
2. Once the desired angle is obtained, lock the headpiece simply by twisting the Flexion / Tilt Knob (No. 5) clockwise and release.

Rotation Feature

1. To unlock the Rotation feature locate the Rotation Release Knob (No. 6) Pull toward the head of the table and twist 1/4 turn clockwise.
2. Gently move the headpiece with the Flexion Assist Handle (No. 8)
3. To lock the Rotation feature locate the Rotation Release Knob (No. 6) twist 1/4 turn counterclockwise and release.

Face Opening Adjustment

1. The Head Cushion's Face Opening can be opened or closed to adjust for the comfort with the Face Opening Lever (No. 7). By pushing slightly down on the Face Opening Lever, slide side to side adjusting the face opening. The Face Opening Lever must be released in one of the eight positions to lock cushions in place.

Flexion Assist Handle

1. The Flexion Assist Handle (No. 8) has many functions including aiding with manual Cervical Flexion Distraction, rotation, lateral side bending, and tilting the headpiece.
2. To adjust the Flexion Assist Handle to desired comfort twist the Flexion Assist Handle locking Knobs on both sides of table. This will unlock the handle for adjustment. Twist in opposite direction to lock.

Chest Cushion

The chest cushion is designed to accommodate large and small abdomen patients, along with the versatility of being a stationary or floating cushion.

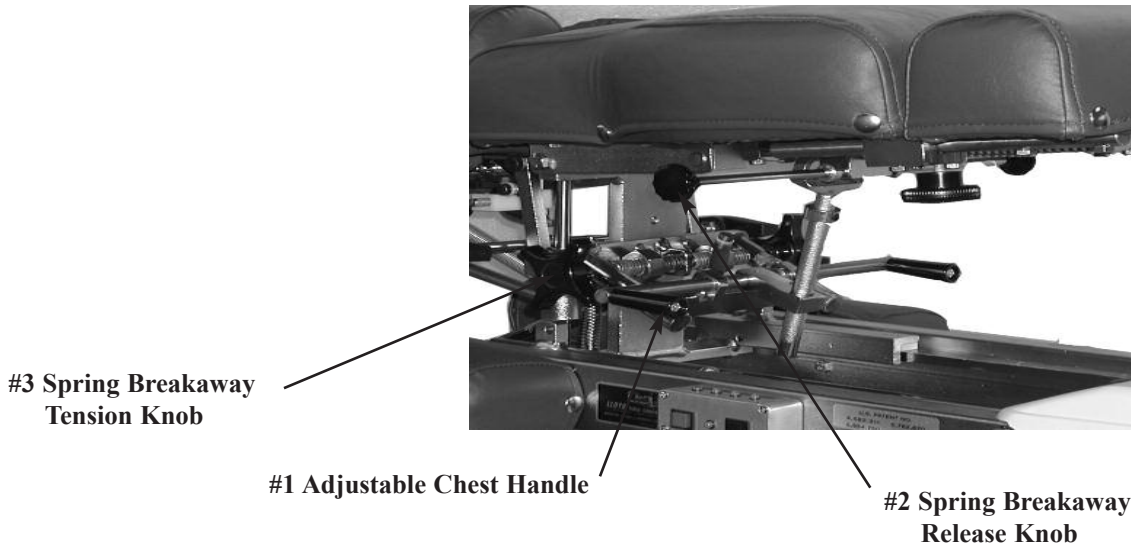

Tilting Chest Cushion Up

1. Lift the rear corners of the cushion.
2. Release the cushion when the desired angle is reached and the cushion will automatically lock into place.

Tilting Chest Cushion Down

1. Support the cushion at the rear corners.
2. Lift on the Adjustable Chest Handle (No. 1) to release the cushion.
3. Slide the cushion to desired angle.
4. Release the Adjustable Chest Handle (No. 1) first and then the cushion to lock into desired height.

Spring Breakaway Chest

To Unlock Spring Breakaway Chest Cushion

1. Pull on Spring Breakaway Knob (No. 2) (facing the right side of the table) to unlock.
2. The resulting floating effect will allow the cushion to gently drop under pressure and spring back when released.

To Lock the Spring Breakaway Cushion

1. Push on Spring Breakaway Knob (No. 2) (facing the right side of the table) to lock. Spring Breakaway will only lock in neutral position

To Increase or Decrease the Tension for Spring Breakaway

1. Rotate the Spring Breakaway Tension Knob (No. 3).
 - A. Left Side: Clockwise - Decrease Tension Counterclockwise - Increase Tension
 - B. Right Side: Clockwise - Increase Tension Counterclockwise - Decrease Tension

Chest- Lumbar Manual Drop Cushion



Chest & Lumbar Drop - Manual

Cocking the Drop Chest or Lumbar Cushion

1. Pull up on the Cocking Handle (No. 1) to cock the desired drop cushion.
2. Adjust the tension on either side by turning the Tension Control Knob (No. 2)

Right side: Clockwise - Decreases Tension Counterclockwise - Increase Tension
Left Side: Clockwise - Increase Tension Counterclockwise - Decrease Tension



CAUTION: THE DROP CUSHION TENSION SHOULD BE CHECKED AND TESTED BEFORE ADJUSTING PATIENT. KEEP FINGERS AWAY FROM BOTTOM OF CUSHION TO AVOID PINCHING.

Lumbar Extension Cushion



The Lumbar Extension Cushion is designed to fill in the gap between the chest and pelvic cushions when table is extended for tall patients. Lumbar Extension Cushion rods can be inserted into the lower chest block as shown above.

Pelvic Cushion Flexion - Distraction

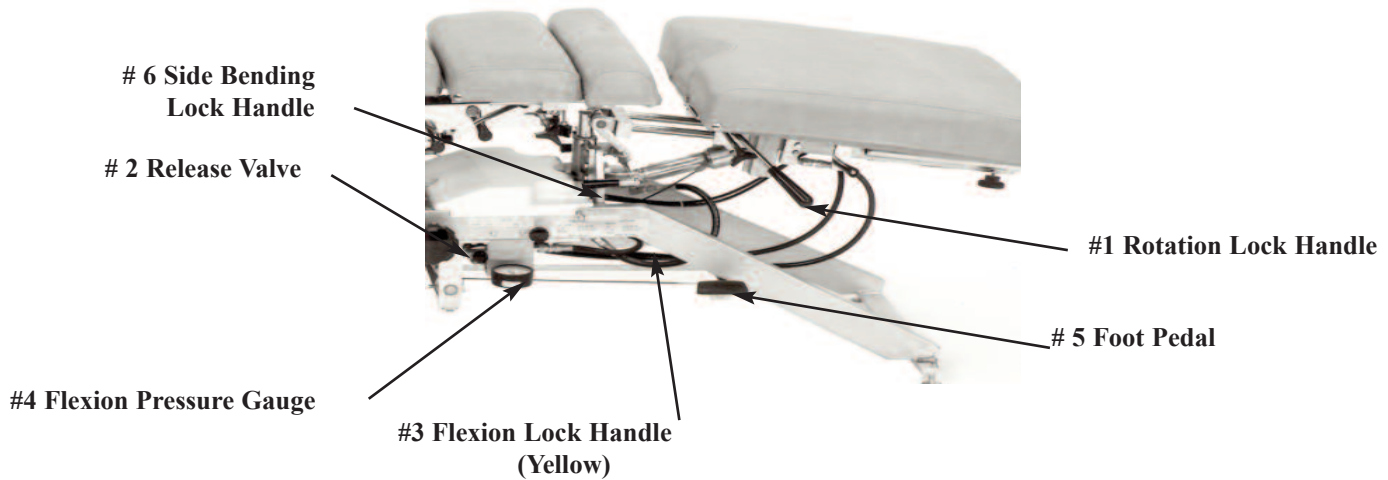

The Pelvic section is designed with the capability of Traction, Lateral Side Bending, Flexion, and optional Rotation



WARNING: THE FOLLOWING PELVIC OPERATIONS ARE ONLY TO BE OPERATED BY A PROFESSIONAL PRACTITIONER, EDUCATED IN THE PROCEDURE OF FLEXION - DISTRACTION AND TRACTION, ON THE LOWER BACK AND SPINE.

Manual Pelvic Flexion Distraction

THE PELVIC FLEXION PRESSURE SHOULD BE CHECKED ON THE GAUGE FOR PROPER SUPPORT AND ADJUSTED, BEFORE ALLOWING A PATIENT ON THE TABLE.

Increase the Flexion Pressure:

1. Turn the Flexion Lock Handle (Yellow)(No. 3) up to unlock manual pelvic flexion.
2. Use the Foot Pedal (No. 5) to increase pressure on the pelvic flexion distraction. Pump with a foot action up and down on the pedal. Observe the Flexion Pressure Gauge (No. 4)



CAUTION: DO NOT EXCEED 800 PSI

Decrease the Flexion Pressure:

1. Turn the Flexion Lock Handle (Yellow)(No. 3) up to unlock manual pelvic flexion.
2. Turn the Release Valve (No. 2) counter clockwise, observe pressure drop on the pressure gauge.



CAUTION: DO NOT REDUCE BELOW 300 PSI

Pelvic Cushion Extension-Retraction

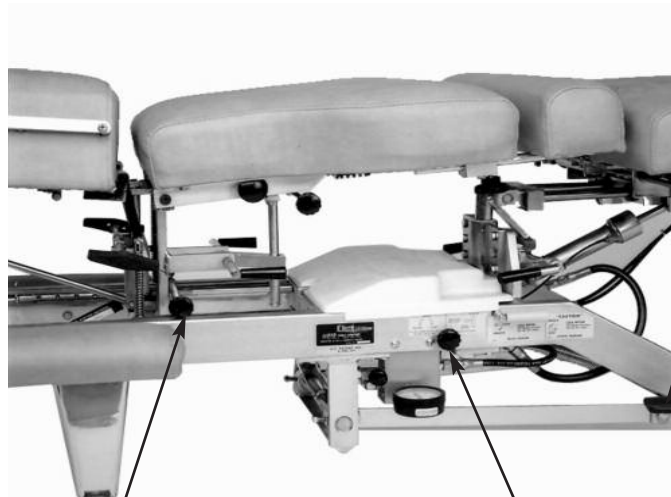

#1 Head & Chest Extension -
Retraction Knob

#3 Foot Pedal

#2 Pelvic Extension - Retraction Knob

Head & Chest Extension-Retraction

1. To extend or retract the head and chest cushions, pull the Chest knob (No 1) to unlock . Slide the head & chest cushion to desired position, and return the lock knob into a locked position, making sure cushions are not secured.

Pelvic Extension-Retraction

Extension:

1. Extension of the cushion is operated on both sides of the table, by pulling or pushing the Control Knob (No. 2) into position.
 - a. Left side operation - pulls out
 - b. right side operation push in.
2. Pump the Foot Pedal (No. 3) to extend the pelvic cushion to the desired position.
3. Lock into position by returning the cotrol knob to it's center position.

Retraction:

1. Retraction of the cushion is operated on both sides of the table, by pulling or pushing the Control Knob (No. 2) into position.
 - a. Left side operation - push in
 - b. right side operation pull out.
2. Pump the Foot Pedal (No. 3) to retract the pelvic cushion to the desired position.
3. Lock into position by returning the cotrol knob to it's center position.

Pelvic Drop

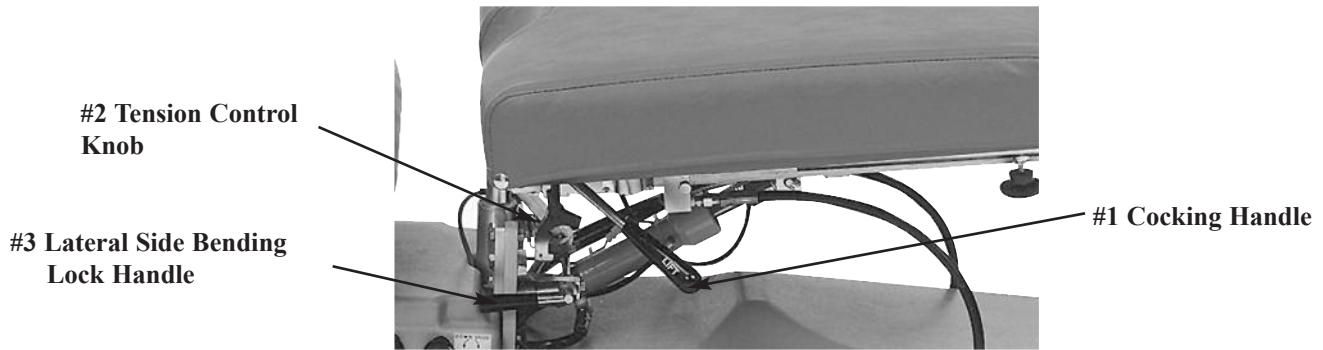

Cocking the Drop Pelvic Cushion

1. Pull up on the Cocking Handle (No. 1) to cock the drop cushion.
2. Adjust the tension on either side by turning the Tension Control Knob (No. 2)

Right side: Clockwise - Decreases Tension Counterclockwise - Increase Tension

Left Side: Clockwise - Increase Tension Counterclockwise - Decrease Tension

CAUTION: THE DROP CUSHION TENSION SHOULD BE CHECKED AND TESTED BEFORE ADJUSTING PATIENT. KEEP FINGERS AWAY FROM BOTTOM OF CUSHION TO AVOID PINCHING



WARNING: MAKE SURE HEAD & CHEST ARE IN LOCKED POSITION AND NOT GLIDING BEFORE PATIENTS IS LAYING ON TABLE.

Pelvic Lateral Side Bending

To Operate Lateral Side Bending Feature:

1. Turn the Lateral Side Bending Handle (No. 3) up, to allow the pelvic cushion to laterally bend.
2. The cushion can be locked at various angles of side bending, laterally moving the cushion in position and rotate the the Lock Handle down to lock in place.

Pelvic Rotation & T - Bar

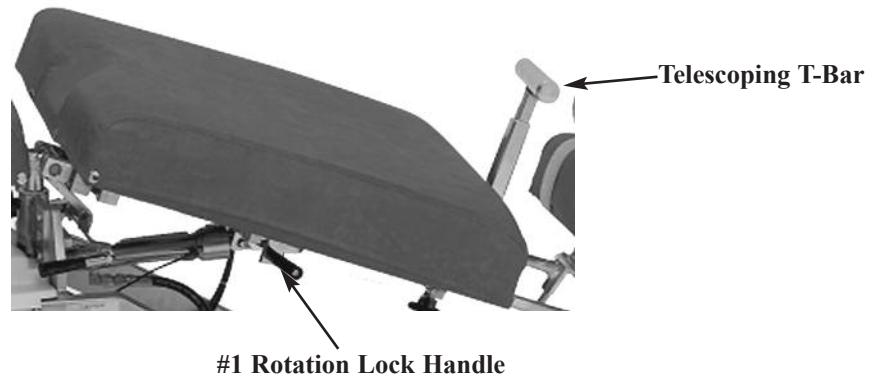

Pelvic Rotation (Optional)

To Unlock the Pelvic Rotation

1. Support the edge of the pelvic cushion.
2. Pull up and slide the Rotation Lock Handle (No. 1) towards the rear of the table to unlock.

To lock the Pelvic Rotation

1. Place the Pelvic Cushion into it's horizontal position.
2. Slide the Lock Handle (No. 1) forward to lock.

Telescoping T-Bar (Optional)

To Change the height of the T-bar

1. While T-Bar is revealed and locked into position simply pinch the red lever against the T-Handle to elevate or lower. Release red lever when desired height is obtained.

To reveal Telescoping T-Bar

1. Simply pivot the handle up until it locks into place. (Fig. 1)

To hide Telescoping T-Bar

1. Pivot the T-Bar down until it is in full horizontal position. (Fig. 2)

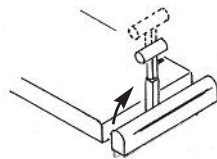

Fig. 1

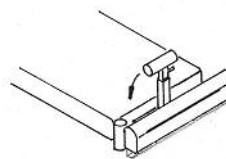

Fig. 2

Ankle Rest



#1 Horizontal Lock Knob

#2 Vertical Lock Lever

Ankle Rest Adjustment

To Extend or Retract the Ankle Rest

1. Loosen the Horizontal Lock Knob (No. 1) and slide the cushion to the desired length.
2. Once the cushion is adjusted, tighten the lock knob.

Vertical Ankle Rest

To Raise the Ankle Rest

1. Simply lift on the sides of the Ankle Rest Cushion.
2. Once the desired height is obtained the cushion will automatically lock into position when released.

To Lower the Ankle Rest

1. From the back end of the table, support the center of the Ankle Rest Cushion with the right hand.
2. With left hand, slide the Vertical Lock Lever (No. 2) towards the left side to release lock.
3. Lower the cushion to desired height, and release the Vertical Lock Lever to lock into place.

Material Parts Assembly



STATIONARY FRAME ASS'Y

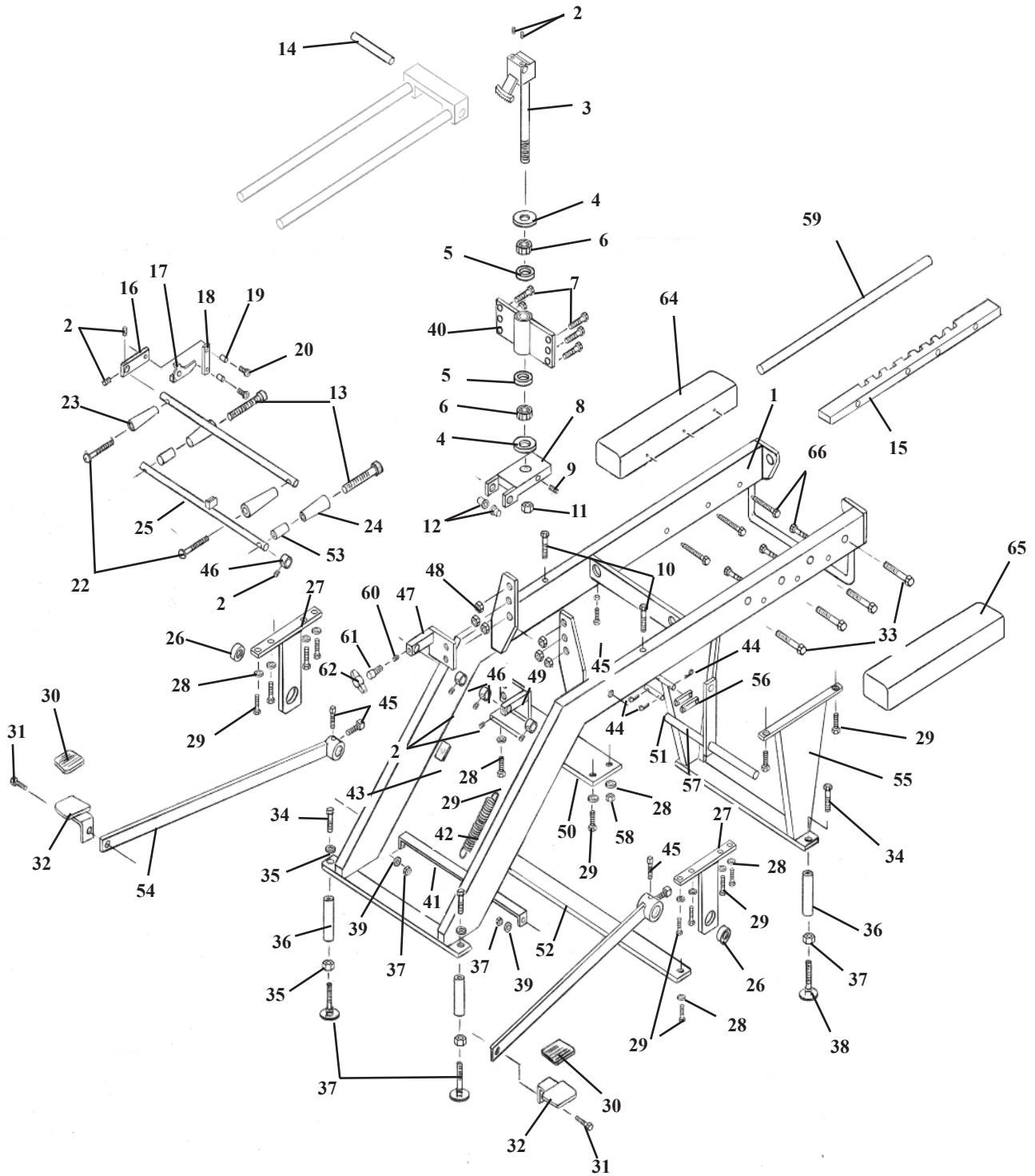

ITEM	PART NO.	DESCRIPTION	QTY.
1A	58000	McMANIS STATIONARY FRAME, 24"	1
1B	57999	McMANIS STATIONARY FRAME, 22"	1
1C	58700	McMANIS STATIONARY FRAME, 18"	1
2	22110	SET SCREW, 1/4 - 20 NC X 1/4	7
3	58004	LOCK ASSEMBLY, PELVIC	1
4	21959	WASHER, FLAT, PLASTIC, 0.665 ID X 1 1/2 OD	2
5	22800	BEARING, RACE, 1 3/8 OD	2
6	22835	ROLLER BEARING, 5/8 ID	2
7	20222	BOLT, HEX HEAD, 5/16 - 18NC X 1 1/4	6
8	58024	SWIVEL BLOCK ASSEMBLY	1
9	22162	SET SCREW, 1/4 - 28 NF X 5/8	1
10	22070	BOLT, HEX HEAD, 1/4 - 20 NC X 3 1/2	3
11	21214	NUT, HEX, 5/8 - 18 NF	2
12	22883	BUSHING, BRASS, FLANGE, 3/8 ID	2
13	20129	BOLT, SOC HD, 1/4 -20 NC X 3 1/2	2
14	58151	LINKAGE ROD, 1/2 RD X 3 1/2	1
15	55573	GUIDE RAIL ASS'Y, 3/8 X 1 X 16 1/2 (McMANIS)	1
16	58089	VALVE ARM, 3/8 X 5/8 X 2 5/16	1
17	58090	VALVE HANDLE, 1/8 X 5/8 X 2 5/8	1
18	58086	LINKAGE BAR, 1/8 X 1/2 X 2	1
19	22860	BUSHING, 3/16 ID X 1/4 OD X 0.160	2
20	21995	SCREW, MACHINE, PAN HEAD, #10 - 24 X 1/2	2
21	58081	ROD, VALVE, 3/8 RD X 14	1
22	22050	SCREW, MACHINE, RD HEAD, 1/4 - 20 NC X 2 1/2	2
23	24021	HANDLE, YELLOW	2
24	24020	HANDLE, BLACK	2
25	58199	LOCK ROD ASSEMBLY, 3/8 RD X 10 9/16	1
26	22848	BRASS BUSHING, 3/4 ID X 7/8 OD X 5/8	2
27A	58005	PUMP PEDAL SUPPORT BRACE (22" & 24")	2
27B	58714	PUMP PEDAL SUPPORT BRACE (18")	2
28	21630	WASHER, STAR, 0.26 ID	8
29	20112	BOLT, HEX HEAD, 1/4 - 28 NF X 5/8	12
30	24245	PAD, PEDAL	2
31	20332	BOLT, HEX HEAD, 3/8 - 16 NC X 1	2
32	58020	PEDAL ASSEMBLY	2
33	20027	BOLT, HEX. HEAD, 1/4-20UNC X 1 1/2	4
34	20220	BOLT, HEX HEAD, 5/16 18 NC X 1	4
35	21755	WASHER, STAR, 5/16 ID	4
36A	53050	ROD, EXTENSION, 1" RD X 4 (4" EXT.)	4
36B	53060	ROD, EXTENSION, 1" RD X 6 (6" EX.)	4
37	21210	NUT, HEX, 3/8 - 16 NC	6
38A	20372	BOLT, ELEVATOR, 3/8 - 16 NC X 1 1/2	4
38B	20412	BOLT, ELEVATOR, 3/8 - 16 NC X 3 (2" EXT.)	4
39	21820	WASHER, STAR, 3/8 ID	2
40	58003	PEDESTAL ASSEMBLY	1
41A	58710	BRACE, PUMP ARM, 1/8 X 1 X 17 1/2	1
41B	58047	BRACE, PUMP ARM, 1/8 X 1 X 15 1/4	1
42	30868	RETURN SPRING, PUMP PEDAL	1
43	58178	CUSHION PAD	2
44	22640	COTTER PIN, 3/32 X 1	4
45	22240	SET SCREW, SQUARE HEAD, 5/16 - 18 NC X 1	5
46	22912	COLLAR, 3/8 ID	4
47	58386	SUPPORT BRACKET ASSEMBLY (LH)	1
48	21112	NUT, HEX, 5/16 - 18 NC	3
49	58385	SUPPORT BRACKET ASSEMBLY (RH)	1
50	58080	MOUNTING PLATE, 5/16 X 2 1/2 X 11 1/8	1
51	58055	LINKAGE, ARM, PUMP, 5/16 RD X 2	2
52	58044	SUPPORT BAR, 3/16 X 1 X 10 3/4	1
53	52192	EXTENSION HANDLE, 1/4 ID X 9/16 OD X 1	2
54A	58007	PUMP ARM ASSEMBLY (22" & 24")	2
54B	58716	PUMP ARM ASSEMBLY (18")	2
55A	57691	LEG ASSEMBLY, 5" FRONT (18" TABLE)	1
55B	57692	LEG ASSEMBLY, 7" FRONT (22" TABLE)	1
55C	57693	LEG ASSEMBLY, 9" FRONT (24" TABLE)	1
56A	58704	DRIVER ASSEMBLY, FOOT PUMP (18" TABLE)	1
56B	58006	DRIVER ASSEMBLY, FOOT PUMP (22" & 24" TABLE)	1
57	58087	LINKAGE PUMP, 7/16 X 5/8 X 2 1/2	2
58	21010	NUT, HEX, 1/4 - 20 NC	2
59	58060	GUIDE ROD, 23/32 X 17 15/16 (McManis)	1
60	58183	SPACER, ACETAL, 1/4 RD X 1/8	1
61	22071	SCREW, MACHINE, SOCKET HEAD, 5/16 - 18 NC X 3/4	1
62	24013	HANDLE, TEE, ROTATION	1
63	40010	ARM REST (LH))	1
64	40030	ARM REST (RH)	1
65	22085	HEX. HD. LAG SCREW, 1/4 X 3	6

DELUXE HEAD CUSHION ASS'Y

NOTE: ITEM #20 IS USED WITH THE STRAIGHT DROP HEAD CUSHION

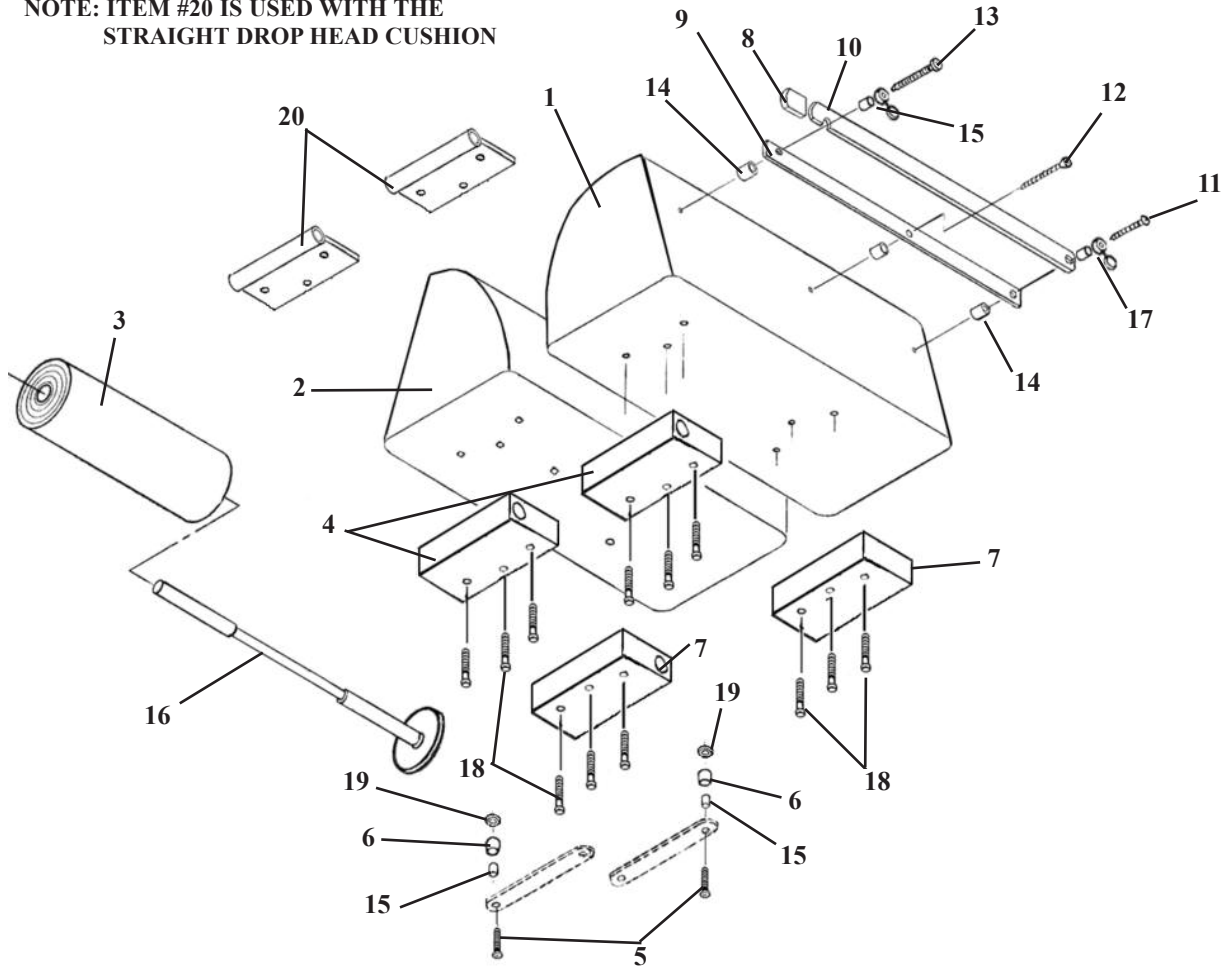

ITEM	PART NO.	DESCRIPTION	QTY
1	40110	CUSHION, HEAD - LEFT HAND	1
2	40130	CUSHION, HEAD - RIGHT HAND	1
3	29999	HEADREST PAPER	1
4	30400	SLIDE BLOCK, FRONT	2
5	22009	OVAL HD. MACHINE SCREW, #10-24 NC X 1 1/2	2
6	57174	SPACER, 3/16 ID X 1/2 OD X 5/8	2
7	30401	SLIDE BLOCK, REAR	2
8	24235	GUARD, CUTTING BAR	2
9	50750	INSIDE CUTTING BAR	1
10	50770	OUTSIDE CUTTING BAR	1
11	22550	RD. HD. WOOD SCREW #14 X 2.00	1
12	22510	FLAT HD. WOOD SCREW, #9 X 1 1/2	1
13	22522	RD. HD. WOOD SCREW, #9 X 2.00	1
14	50720	SPACER, PAPER CUTTER, 3/8 ID X 1/2 OD	3
15	22860	BUSHING, 3/16 ID x 1/4 OD	3
16	50778	PAPER HANGER ASS'Y, w/ Washer	1
17	21610	FLAT WASHER, 3/16 ID X 1/2 OD	1
18	22003	OVAL HD. MACHINE SCREW, #10 - 24 NC X 3/4	12
19	21510	FLAT WASHER, 3/16 ID X 1/2 OD	2
20	57155	GUIDE TUBE ASS'Y, FRONT	2

DELUXE HEAD FRAME ASS'Y

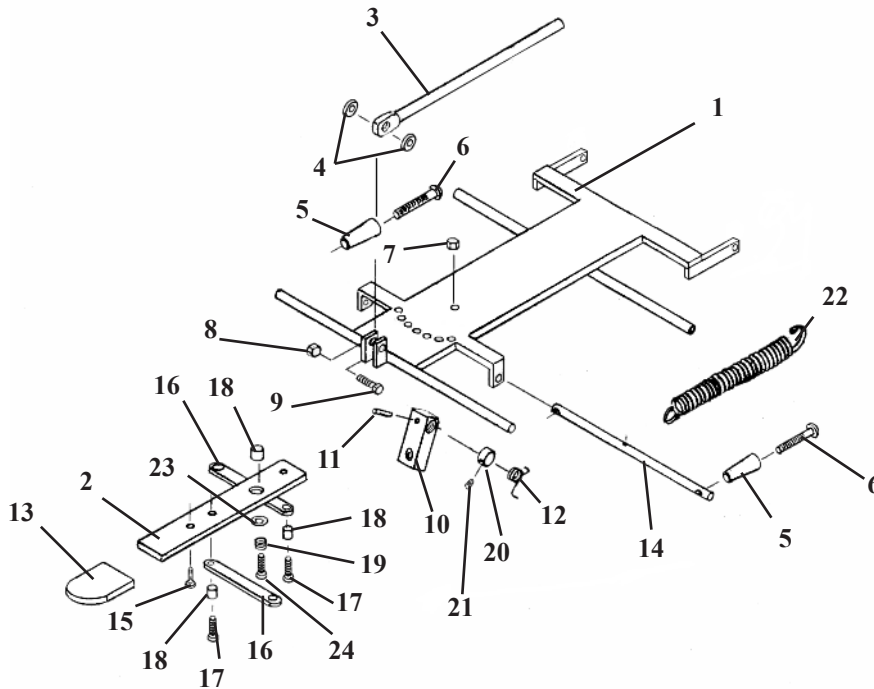

ITEM	PART NO.	DESCRIPTION	QTY.
1	56051	FASTENER PLATE ASS'Y	1
2	57221	ADJUSTMENT ARM	1
3	55929	CENTER BAR	1
4	21616	PLASTIC FLAT WASHER, ¼ ID X ¾ OD	2
5	24020	HANDLE	2
6	22050	RD. HD. MACHINE SCREW, ¼-20 UNC X 2 ½	2
7	21450	HEX. NUT, #10-24 UNC	1
8	21020	HEX. NUT, ¼-28 UNF	1
9	20115	HEX. HD. BOLT, ¼-28 UNF X 1.00	1
10	54107	ADJUSTMENT BLOCK	1
11	22670	ROLL PIN, 1/8RD. X ¾	1
12	30870	TORSION SPRING	1
13	24236	PLASTIC CAP	1
14	57205	ADJUSTMENT ROD, 7/16 RD. X 9 5/8	1
15	22300	RD. HD. MACHINE SCREW, #8-32 UNC X ¼	1
16	57175	LINKAGE BAR, 1/8 X ½ X 3 9/16	2
17	21995	PAN HD. MACHINE SCREW, #10-24 UNC X ½	3
18	22860	BUSHING, 3/16ID X 1/4 OD X .160	3
19	30722	COMPRESSION SPRING, .235 ID X .5/16 OD X ½	1
20	22912	COLLAR, 3/8 ID	1
21	22110	SET SCREW, ¼-20 UNC X ¼	1
22	30785	TENSION SPRING, ½ ID X 5/8 OD X 7 1/8 (HYLO ONLY)	1
23	21610	WASHER, .26 ID X ½ OD	1
24	22003	PAN HD. MACHINE SCREW, #10-24 UNC X ¾	1

STANDARD CHEST CUSHION ASS'Y SPRING BREAKAWAY

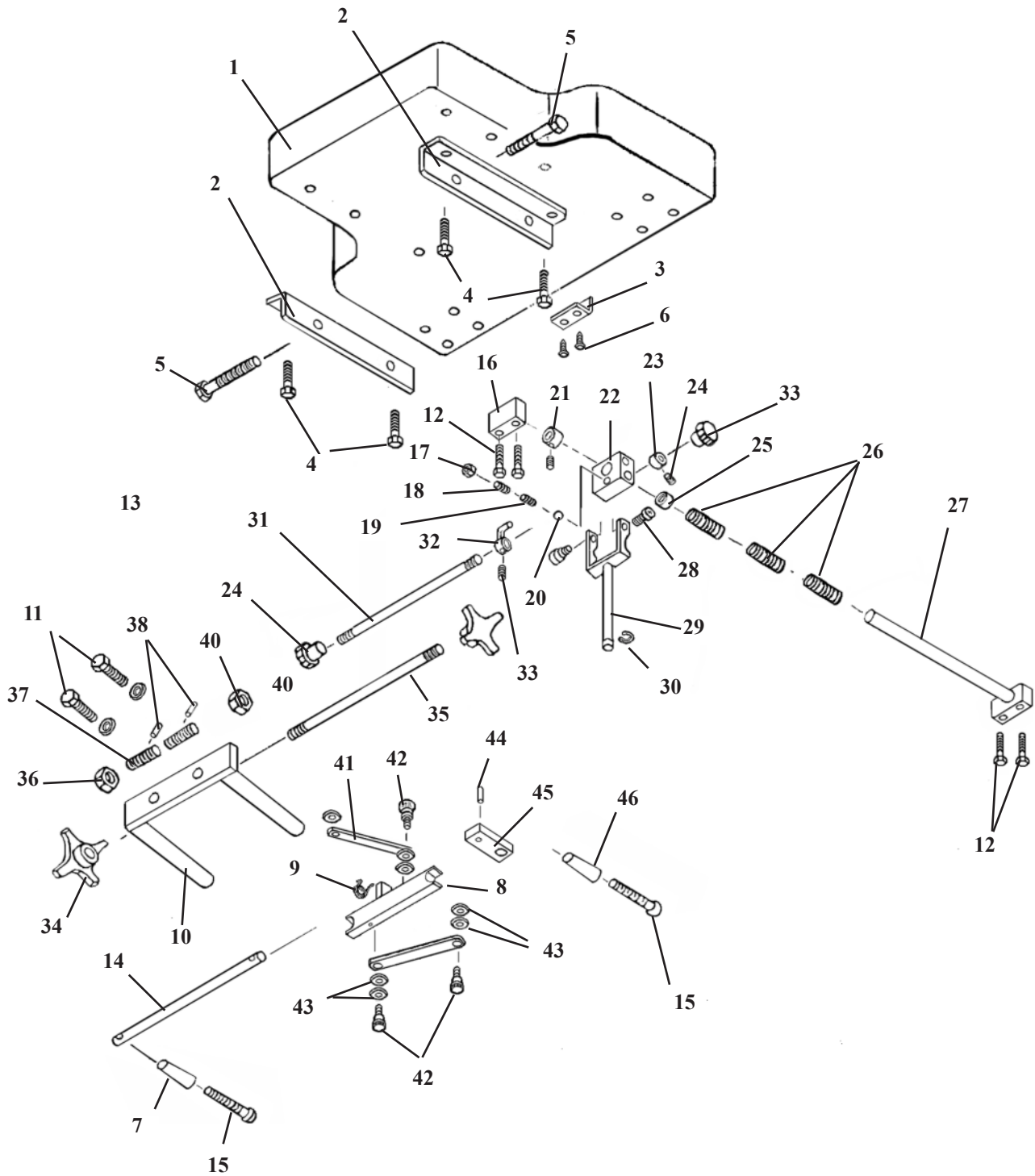

CHEST CUSHION ASS'Y

SPRING BREAKAWAY - ADJUSTABLE TENSION

ITEM	PART NO.	DESCRIPTION	QTY.
1A	40210	CUSHION, CHEST – STANDARD	1
1B	40230	CUSHION, CHEST – WIDE	1
2	56416	BRACE, CUSHION 1/8 x 1 1/4 sq. x 6	2
3	56202	GUARD, 3/4 X 3/4 X 4 1/2	1
4	20022	BOLT, HEX HEAD, 1/4 - 20 NC X 1	6
5	20361	BOLT, HEX HEAD, 3/8 – 16 NC X 1 3/4	2
6	22468	SCREW, SHEET METAL, #10 X 7/8	2
7	24020	HANDLE	2
8	51075	SLIDE BRACKET ASSEMBLY	1
9	30870	TORSION SPRING	1
10	51074	C – FRAME ASS'Y	1
11A	20332	BOLT, HEX HEAD, 3/8 – 16 NC X 1	2
11B	55826	BOKT, HEX HEAD, 3/8-16 NC X 1 3/4 (Flexion Head)	2
12	20052	BOLT, HEX HEAD, 1/4 - 20 NC X 1 3/4	10
13	21820	WASHER, STAR, 3/8 ID X 11/16 OD	2
14	51230	ADJUSTMENT ROD	1
15	22050	MACHINE SCREW, RD. HD, 1/4-20 UNC X 2 1/2	2
16	51110	SUPPORT BLOCK	1
17	21012	NUT, JAM, 1/4 - 20 NC	1
18	22120	SET SCREW, 1/4 - 20 NC X 1/2	1
19	30715	SPRING, COMPRESSION, 3/16 ID X 5/32 OD	1
20	22702	BALL, STEEL, 3/16 DIA	1
21	22940	COLLAR, 5/8 ID X 1 3/32 OD	1
22	51090	YOKE BLOCK	1
23	22922	COLLAR, 5/16 ID X 5/8 OD	1
24	24150	KNOB, LOCK	2
25	22854	BUSHING, 5/8 ID X 23/32 OD	1
26	30793	SPRING, COMPRESSION, 11/16 ID X 15/16 OD X 3 1/8	3
27	51068	SUPPORT ROD ASSEMBLY	1
28	20197	BOLT, SOCKET HD, 5/16 – 18 NC SHOU 3/8 X 3/8	2
29	56190	FORK ASS'Y	1
30	24286	SNAP RING, 9/16	1
31	51150	LOCK ROD, 5/16 RD X 13 9/16	1
32	50570	LOCK PIN ASS'Y	1
33	22090	SET SCREW, #10 – 32 NF X 3/16	2
34	24154	KNOB, ADJUSTMENT	2
35	51057	ROD, ADJUSTMENT, 3/8 RD X 7 1/4	1
36	51064	NUT, ADJUSTMENT (RH), 5/8 ACME THD	1
37	51058	WORM SCREW (RH), 5/8 ACME THD	1
38	22675	ROLL PIN, 1/8 X 3/4	2
39	51059	WORM SCREW (LH), 5/8 ACME THD	1
40	51063	NUT, ADJUSTMENT (LH), 5/8 ACME THD	1
41	51067	ARM, LINKAGE, 1/4 X 1/2 X 3 1/2	2
42	20002	BOLT, SOCKET HD, 1/4 - 20 NC SHOU 5/16 X 3/8	4
43	21760	WASHER, PLASTIC, 0.315 ID X 1/2 OD X 0.032	8
44	22660	ROLL PIN, 1/8 X 5/8	1
45	57737	BLOCK, ADJUSTMENT	1

I - FRAME ASSEMBLY DELUXE, FORWARD MOTION & FLEXION HEAD

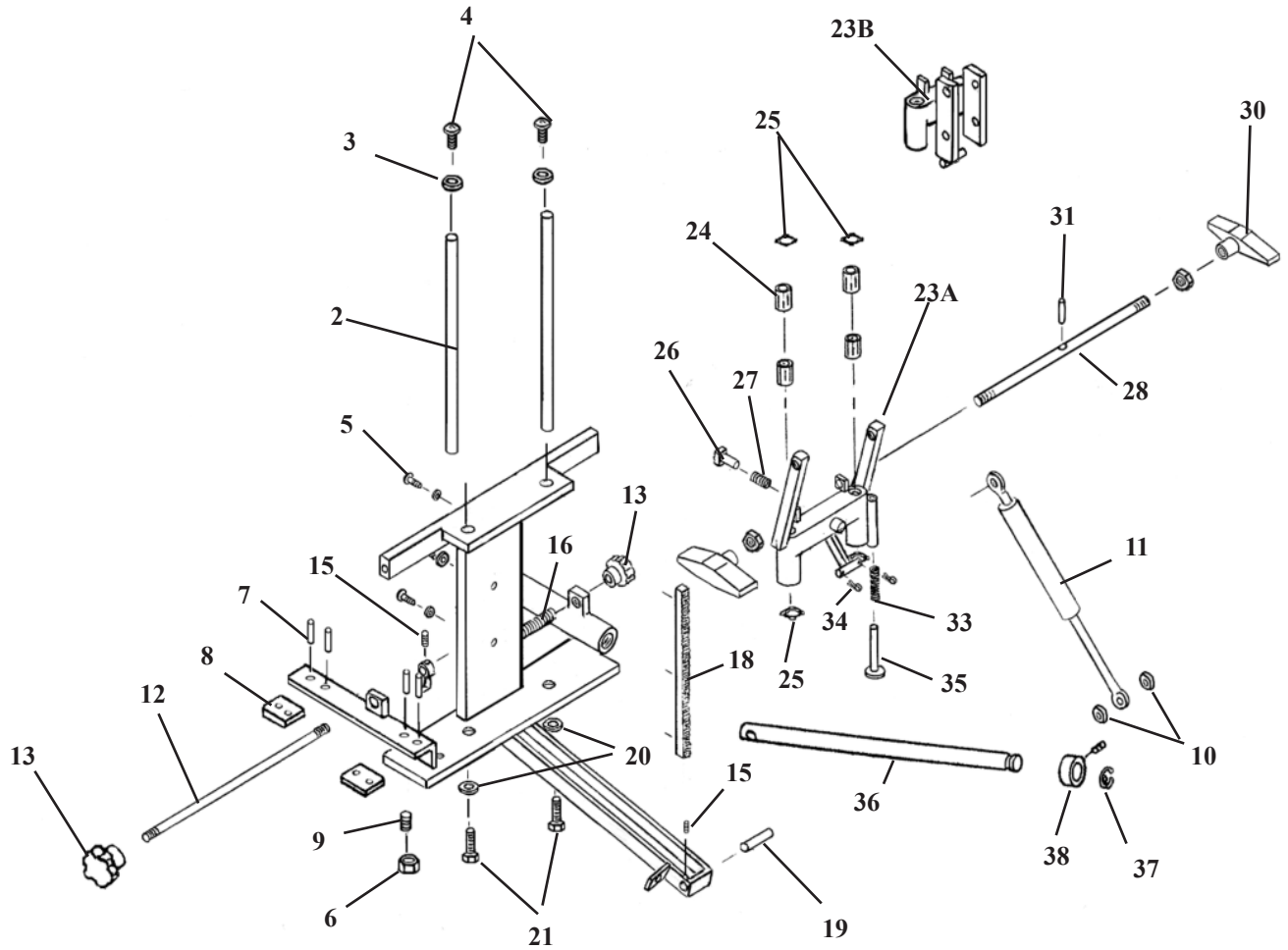

I - FRAME ASSEMBLY

DELUXE, FORWARD MOTION & FLEXION HEAD

ITEM	PART NO.	DESCRIPTION	QTY.
1	55941	I-FRAME ASSEMBLY	1
2	50872	GUIDE ROD, ½ RD X 7 7/8	2
3	21620	WASHER, FLAT, 1/4ID X 9/16OD	2
4	22013	MACHINE SCREW, BUTTON HD. ¼-20UNC X ½	2
5	21975	MACHINE SCREW, PAN HD. #6-32UNC X ½	3
6	21110	JAM NUT, 5/16-18UNC	1
7	22657	ROLL PIN, 1/8 X 3/8	4
8	55944	SLIDE PLATE,	2
9	22233	SET SCREW, (Brass Tip) 5/16-18UNC X 5/8	1
10	56006	SPACER, 3/8ID X 1/2OD X 3/16	2
11A	30297	PRESSURE CYL. 40LB (Deluxe Hd.)	1
11B	30296	PRESSURE CYL. 50LB (F/M 89, Straight Drop, Flexion Hd.)	1
12	50531	EXTENSION RELEASE ROD, 5/16RD X 10	1
13	24150	LOCK KNOB	2
14	50570	LOCK PIN ASS'Y	1
15	22090	SET SCREW, #10-32UNF X 3/16	1
16	30770	COMPRESSION SPRING, 3/8ID X 6 13/16	1
17	20332	HEX HD BOLT, 3/8-16UNC X 1	2
18	56019	GEAR RACK	1
19	56002	SUPPORT PIN, 5/16 X 1 5/16	1
20	21630	STAR WASHER, ¼ ID X ½ OD	2
21	20007	HEX HD BOLT, ¼-20UNC X 5/8	2
22	22110	SET SCREW, #10-32 UNC X 3/16	1
23A	56045	SHUTTLE ASS'Y (F/M89, Straight Drop, & Deluxe Hd.)	1
232B	55750	SHUTTLE ASS'Y, (Flexion Hd.)	1
24	22891	BUSHING, ½ RD. X 1.00	4
25	24050	SPRING CLIP (External Teeth)	4
26	56064	LOCK PIN ASS'Y, (F/M 89 & Deluxe Hd.)	1
27	30750	COMPRESSION SPRING, 9/32ID X ¾	1
28	55949	LOCK ROD, 3/8 RD X 11	1
29	21211	HEX NUT, 3/8-16 UNC	2
30	24186	TENSION KNOB	2
31	22675	ROLL PIN, 1/8 X ¾	1
32	22660	ROLL PIN 1/8 X 5/8	1
33	30740	COMPRESSION SPRING, 5/16 ID 4 ¾	1
34	22640	COTTER PIN, 3/32 X 1	2
35	55959	PLUNGER ASSEMBLY	1
36	54108	GUIDE ROD, ½ RD X 13 13/16	1
37	24285	SNAP RING, ½ DIA	1
38	22913	SET COLLAR, ½ ID	1

ANKLE REST ADJUSTABLE HEIGHT

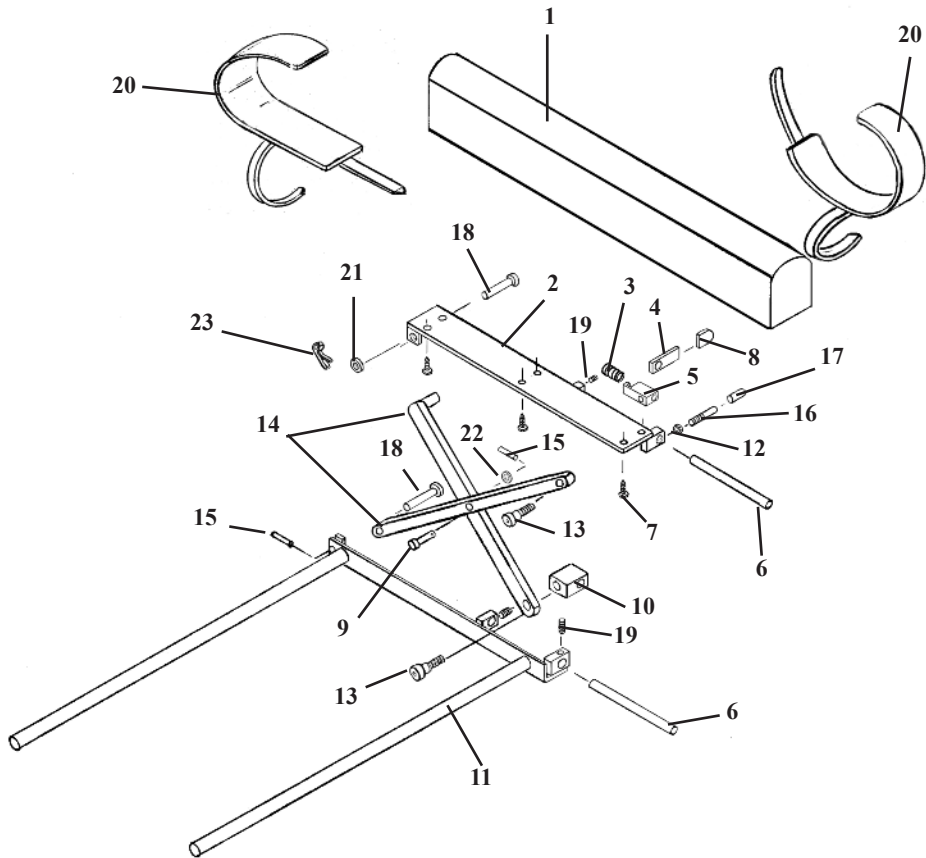

ANKLE REST ADJUSTABLE HEIGHT

ITEM	PART NO.	DESCRIPTION	QTY.
1	40410	ANKLE REST CUSHION	1
2	56507	BASE PLATE	1
3	30774	COMPRESSION SPRING	1
4	56519	LOCK HANDLE	1
5	56525	GUIDE BLOCK	1
6	56518	GUIDE ROD	2
7	22468	SCREW, WOOD, RD HEAD, #10 X 7/8	6
8	24236	GUARD, TEE HANDLE	1
9	22610	PIN, CLEVIS, 5/16 X 7/8	1
10	56539	GUIDE BLOCK	1
11	56515	SLIDE FRAME ASS'Y	1
12	21010	NUT, HEX, 1/4 - 20 UNC	1
13	20002	BOLT, SOCKET, SHOULDER, 1/4 - 20 UNC X 3/4	2
14	56512	LINKAGE ARM ASSEMBLY	2
15	22660	ROLL PIN, 1/8 X 5/8	2
16	52190	EXTENSION ROD	1
17	24415	PLASTIC CAP	1
18	22615	PIN, CLEVIS, 5/16 X 2	2
19	22110	SET SCREW, 1/4 - 20 UNC X 1/4	3
20	697550	STRAP, ANKLE (PAIR)	1
21	21710	WASHER, FLAT, 5/16 ID	1
22	21760	WASHER, FLAT, PLASTIC, 0.315 ID X 1/2 OD	1
23	22640	COTTER PIN	1

HYDRAULICS

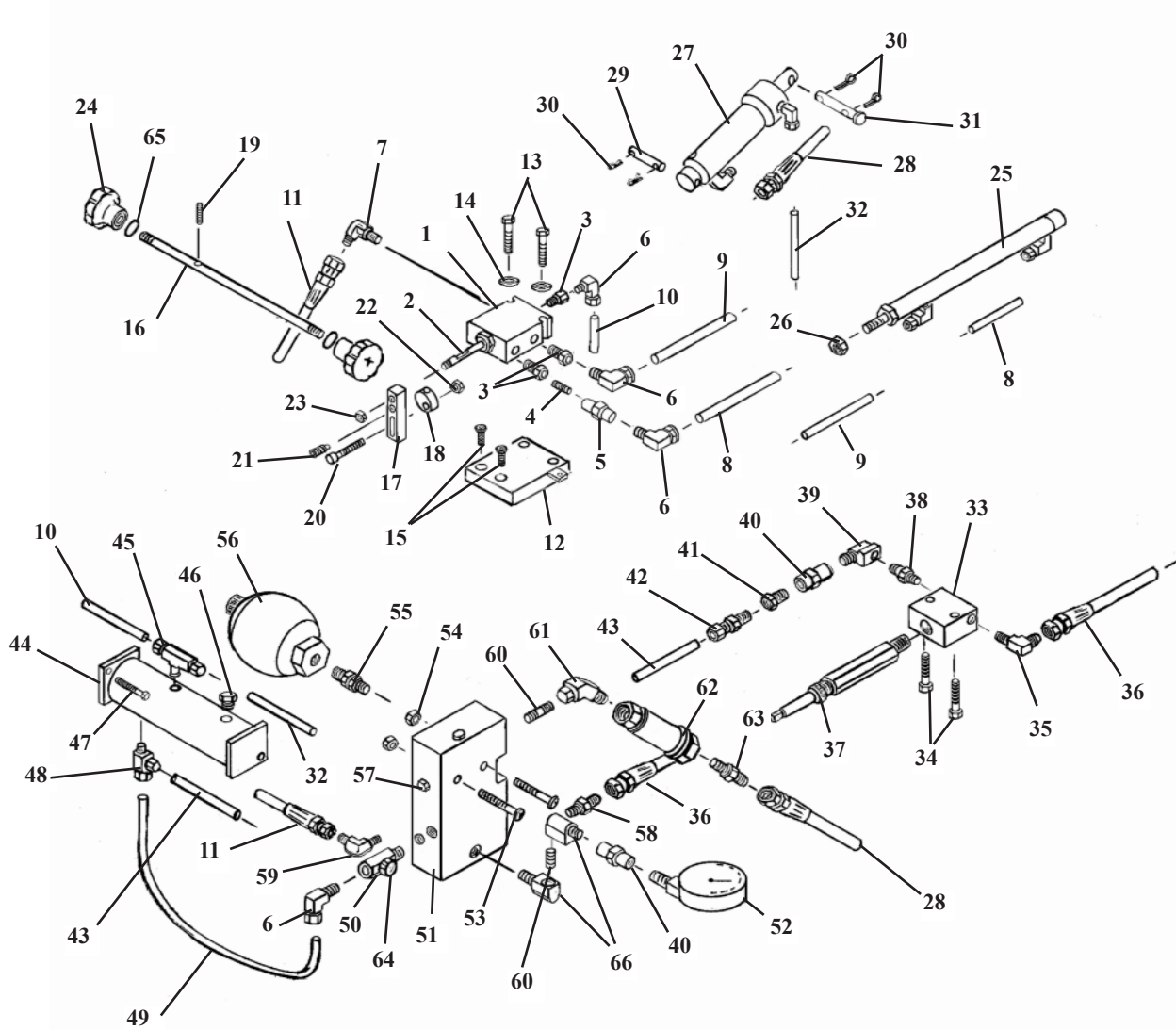

HYDRAULICS

ITEM	PART NO.	DESCRIPTION	QTY.
1	23582	VALVE BLOCK, 4-WAY	1
2	23584	VALVE BLOCK, 4-WAY, 3-POSITION	1
3	23450	FITTING, PIPE, ¼-1/8 REDUCER	3
4	23310	FITTING, PIPE NIPPLE, 1/8 CLOSE	1
5	23020	COUPLER, FEMALE, 1/8	1
6	23129	FITTING, 90 DEG. 1/8 NPT – ¼ COMP	4
7	23110	FITTING, 90 DEG, 1/8 MALE – JIC	1
8	23635	HOSE, LEGRIS, ¼ X 35 (VERSA VALVE-PELVIC EXT.)	1
9	23620	HOSE, LEGRIS, ¼ X 25 (VERSA VALVE-PELVIC RECT.)	1
10	23607	HOSE, LEGRIS, ¼ X 8 (VERSA VALVE-RESERVOR)	1
11	45270	HOSE, HYD. 3/16 X 18 (VERSA VALVE-MONO BLOCK)	1
12	58192	SPACER PLATE,	1
13	20054	BOLT, HEX HD. ¼-20 UNC X 2	2
14	21620	WASHER, FLAT, ¼ ID X 9/16 OD	2
15	22002	MACHINE SCREW, FLAT HD. #10-24 UNC X ¼	2
16	58116	ADJUSTMENT ROD, 5/16 RD X 14 ½	1
17	58160	CONTROL ARM	1
18	58188	COUPLER DISC.	1
19	22095	SET SCREW #10-24 UNC X ½	1
20	22004	MACHINE SCREW, SOCKET HD. #10-24 UNC X 1	1
21	22121	SET SCREW, ¼-20 UNC X ½	1
22	21450	HEX. NUT, #10-24 UNC	1
23	21460	HEX. NUT, #10-32 UNF	1
24	24150	LOCK KNOB	2
25	624980	CYLINDER, PELVIC EXT. / RET.	1
26	21020	NUT, HEX. ¼-28 UNF	1
27	624920	CYLINDER, PELVIC FLEXION	1
28	45485	HOSE, HYD. ¼ X 16 (BALL VALVE – FLEX CYL.)	1
29	58085	CYLINDER PIN	1
30	22640	COTTER PIN	3
31	22620	CLEVIS PIN, 5/16 X 2 3/4	1
32	23617	HOSE LEGRIS ¼ X 19 ½	1
33	58079	BLOCK, PUMP	1
34	20250	HEX. HD. BOLT, 5/16 – 18 UNC X 2	2
35	23150	FITTING , 90 DEG, ¼ NPT – JIC	1
36	45215	HOSE HYD. 3/16 X 10 ½ (PUMP BLK – MONO BLK)	1
37	45600	PUMP ASSEMBLY	1
38	23565	CHECK VALVE	1
39	23160	FITTING, 90 DEG. – ¼ ST.	1
40	23050	FITTING, FEMALE COUPLER, ¼	2
41	23450	FITTING, PIPE, ¼-1/8 REDUCER	1
42	23032	COUPLER, MALE COMPRESSION, 1/8 X ¼	2
43	23604	HOSE, LEGRIS, ¼ X 4 ½ (PUMP BLK-RESERVOIR)	1
44	58021	RESERVOIR TANK	1
45	23219	FITTING, TEE COMPRESSION, 18 NPT X ¼ COMP	1
46	23412	VENT PLUG, 1/8 NPT	1
47	20120	HEX. HD. BOLT, ¼-28 UNF X 1	3
48	23209	FITTING, TEE ¼ - 1/8 NPT	1
49	23608	HOSE, LEGRIS, ¼ X 9 (RESERVOIR-MONO BLOCK)	1
50	23580	NEEDLE VALVE	1
51	23556	MONO BLOCK	1
52	24480	PRESSURE GAUGE	1
53	22060	MACHINE SCREW, RD HD. ¼-20 UNC X 3	2
54	21010	HEX. NUT, ¼-20 UNC	2
55	23080	COUPLER #8	1
56	23459	ACCUMULATOR	1
57	23532	VALVE, CHECK	2
58	23044	COUPLER, MALE CONNECTOR, #4-1/4 JIC	1
59	23155	FITTING, 90 DEG. #4-1/4JIC	1
60	23360	PIPE NIPPLE, ¼-1 ½	1
61	23105	FITTING, 45 DEG. ¼ NPT	1
62	23560	VALVE, BALL	1
63	23045	COUPLER, MALE, ¼ NPT – ¼ JIC	1
64	24179	RELEASE KNOB	1
65	24004	O-RING	2
66	23161	FITTING, 90 DEG. ¼ ST. – 1/8 FEMALE (18” & 20” TABLES)	2

STRAIGHT DROP HEAD ASS'Y

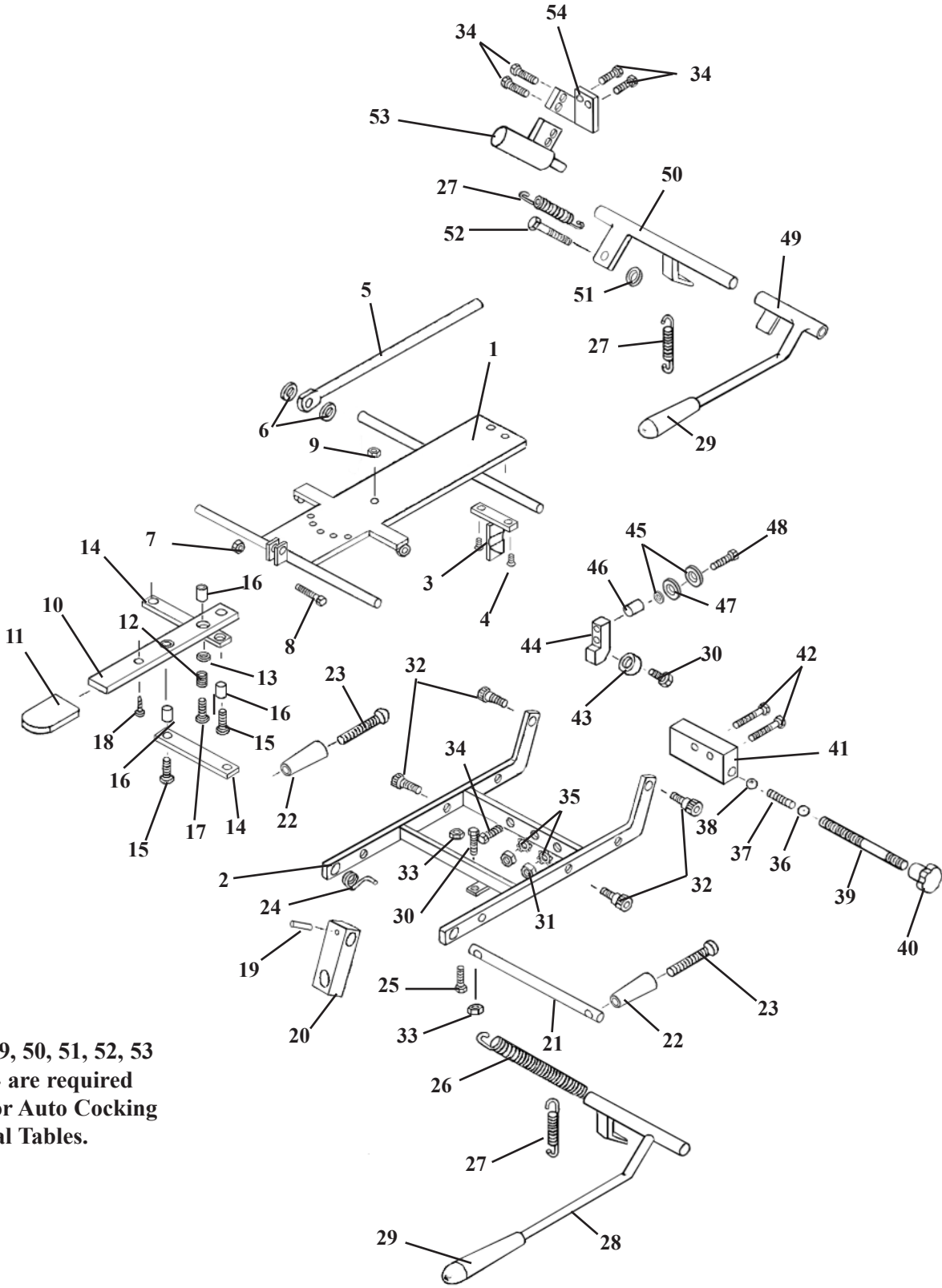

Items 49, 50, 51, 52, 53 and 54 are required only for Auto Cocking Cervical Tables.

STRAIGHT DROP HEAD ASSEMBLY

ITEM	PART NO.	DESCRIPTION	QTY.
1	56011	FASTENER PLATE ASS'Y, '89 STRAIGHT DROP HD	1
2	57201	OUTSIDE DROP FRAME ASS'Y, '89 FM HEAD	1
3	55850	TEE WEDGE ASSEMBLY	1
4	22017	SCREW, MACHINE, FLAT HEAD, ¼ - 20 UNC X ½	2
5	55929	CENTER ROD ASSEMBLY	1
6	21616	WASHER, PLASTIC, ¼ ID X ¾ OD	2
7	21020	NUT, HEX, ¼ - 28 UNF	1
8	20115	BOLT, HEX HEAD, ¼ - 28 UNF X ¾	1
9	21450	NUT, HEX, # 10 - 24 UNC	1
10	57221	ADJUSTMENT ARM, 1/8 X 7/8 X 8	1
11	24236	GUARD, TEE HANDLE	1
12	30722	SPRING, COMPRESSION, 0.235 ID X 5/16 OD X ½	1
13	21610	WASHER, PLASTIC, 0.26 ID X ½ OD	2
14	57175	LINKAGE BAR, 1/8 X ½ X 3 13/16	2
15	21995	SCREW, MACHINE, PAN HEAD, # 10 - 24 UNC X ½	2
16	22860	BUSHING, 0.465 ID X 9/16 OD X 19/32	3
17	22003	SCREW, MACHINE, PAN HEAD, # 10 - 24 UNC X ¾	1
18	22300	SCREW, MACHINE, # 8 - 32 UNC X ¼	1
19	22660	ROLL PIN, 1/8 X 5/8	1
20	54107	BLOCK, ADJUSTING, '89 HEAD, 5/8 X 1 X 2 15/16	1
21	57205	ROD, TILT HANDLE, 3/8 RD X 5 ½	1
22	24020	HANDLE	2
23	22050	SCREW, MACHINE, RD HEAD, ¼ - 20 - UNC X 2 ½	2
24	30871	SPRING, TORSION	1
25	20024	BOLT, SOCKET HEAD, ¼ - 20 UNC X 1 ¼	1
26	30785	SPRING, TENSION (HYLO TABLES)	1
27	30725	SPRING, EXTENSION, ¼ ID X 5/16 X 1	1
28	56067	COCKING HANDLE ASS'Y, F/M '89 HEAD	1
29	24010	HANDLE GRIP	1
30	20020	BOLT, HEX HEAD, ¼ - 20 UNC X 1 ¼	2
31	21112	NUT, HEX, 5/16 X 18 UNC	2
32	20197	BOLT, SOCKET HEAD, 5/16 - 18 UNC, SHOULDER, 3/8 X 3/8	4
33	21012	NUT, JAM, ¼ - 20 UNC	2
34	20007	BOLT, HEX HEAD, ¼ - 20 UNC X 5/8	6
35	21755	WASHER, STAR, 5/16 ID	2
36	22701	BALL, STEEL, ¼ RD	1
37	30721	SPRING, COMPRESSION, 0.175 ID X 23/64 OD X 1 1/8	1
38	22700	BALL, BEARING, 3/8 RD	1
39	57184	STUD, TENSION ADJUSTMENT, 5/16 RD X 2 ¼	1
40	24150	KNOB, TENSION ADJUSTMENT	1
41	55849	BLOCK, DROP, 1 X 1 7/16 X 2 3/32	1
42	20235	BOLT, HEX HEAD, 5/16 - 18 UNC X 1 ¾	2
43	22805	BALL, BEARING, ¼ ID	1
44	57102	BLOCK, BACKER BEARING, STRAIGHT DROP, ¾ X 9/16 X 1 ¼	1
45	21620	WASHER, FLAT, ¼ ID X 9/16 OD X 3/16	2
46	50720	SPACER, 3/8 ID X ½ OD X ½	1
47	21710	WASHER, FLAT, 5/16 ID X 0.688 OD	1
48	20022	BOLT, HEX HEAD, ¼ - 20 UNC X 1	1
49	56069	COCKING HANDLE ASS'Y, F/M '89 HEAD (AUTO DROP)	1
50	57140	COCKING LEVER ASS'Y, F/M '89 HEAD (AUTO DROP)	1
51	21210	NUT, HEX, 3/8 - 16 UNC (AUTO DROP)	1
52	20320	BOLT, HEX HEAD, 3/8 - 16 UNC X ¾ (AUTO DROP)	1
53	625020	COCKING CYLINDER, ¾ RD w/FITTINGS (AUTO DROP)	1
54	57194	BRACKET, CYLINDER ADAPTER (AUTO DROP)	1

FORWARD MOTION HEAD FRAME ASS'Y

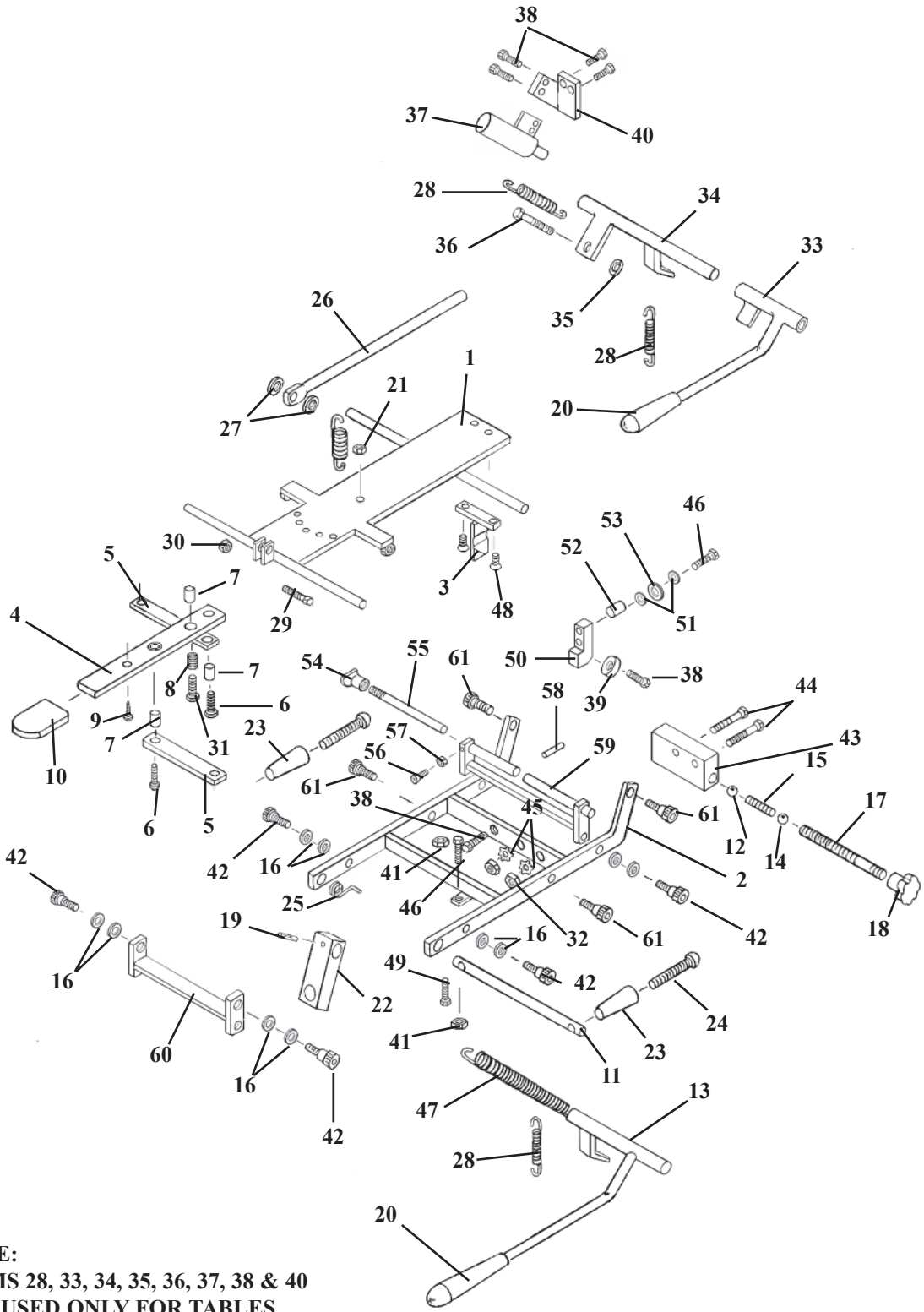

NOTE:
ITEMS 28, 33, 34, 35, 36, 37, 38 & 40
ARE USED ONLY FOR TABLES
WITH
AUTO COCKING CERVICAL.

FORWARD MOTION HEAD FRAME

ITEM	PART NO.	DESCRIPTION	QTY
1	56059	OUTSIDE DROP FRAME ASS'Y	1
2	57201	OUTSIDE HEAD FRAME ASS'Y	1
3	55850	TEE WEDGE	1
4	57221	ADJUSTMENT ARM, HEAD CUSHION	1
5	57175	LINKAGE BAR, 1/8 X 1/2 X 3 9/16	2
6	21995	PAN HD. MACHINE SCREW, #10-24 NC X 1/2	2
7	22860	BUSHING, 3/16 ID X 1/4 OD	3
8	30722	COMPRESSION SPRING, 1/4 ID X 5/16 OD	1
9	22300	MACHINE SCREW, #8-32 NC X 1/4	1
10	24236	PLASTIC CAP	1
11	57205	SUPPORT ROD, 3/8 RD. X 6 1/16	1
12	22700	BALL, STEEL, 3/8 DIA	1
13	56067	COCKING LEVER ASS'Y	1
14	22701	BALL, BEARING, 1/4 DIA	1
15	30710	COMPRESSION SPRING, 9/64 ID X 1/4 OD	1
16	21760	PLASTIC WASHER, 5/16 ID X 1/2 OD	12
17	57184	TENSION ADJUSTMENT SCREW, 5/16 RD. X 2 3/4	1
18	24150	KNOB, TENSION ADJUSTMENT	1
19	22660	ROLL PIN, 1/8 X 5/8	1
20	24010	COCKING HANDLE	1
21	21450	HEX NUT, #10-24 NC	1
22	54107	ADJUSTING BLOCK, 5/8 X 1.00 X 2 15/16	1
23	24020	ADJUSTMENT HANDLE	2
24	22050	MACHINE SCREW, RD. HD., 1/4-20 NC X 2 1/2	2
25	30871	TORSION SPRING	1
26	55929	CENTER BAR,	1
27	21616	WASHER, FLAT, PLASTIC, 1/4 ID X 3/4 OD	2
28	30725	RETURN SPRING	2
29	20115	HEX.HD BOLT, 1/4-28 NF X 3/4	1
30	21020	NUT, HEX, 1/4-28 NF	1
31	22003	PAN HD. SCREW, #10-24 UNC X 3/4	1
32	21112	HEX.NUT, 5/16-18 UNC	2
33	56069	COCKING HANDLE ASS'Y (AUTO DROPS)	1
34	57140	COCKING LEVER ASS'Y (AUTO DROPS)	1
35	21210	HEX.NUT, 3/8-16 NC (AUTO DROPS)	1
36	20320	HEX.BOLT, 3/8-16 NC X 3/4 (AUTO DROPS)	1
37	625020	COCKING CYLINDER, 3/4 (AUTO DROPS)	1
38	20007	HEX.HD.BOLT, 1/4-20 NC X 5/8 (AUTO DROPS)	6
39	22805	BEARING	1
40	57194	CYL.MT.BRACKET (AUTO DROPS)	1
41	21012	NUT, JAM, 1/4-20 UNC	2
42	20002	SOCKET HD. BOLT, 1/4-20 NC X 1 1/4	6
43	55849	DROP BLOCK	1
44	20235	HEX.HD.BOLT, 5/16-18 NC X 1 3/4	2
45	21755	WASHER, STAR 5/16ID	2
46	20020	HEX.HEAD BOLT, 1/4-20 NC X 1 1/4-GR 5	3
47	30785	TENSION SPRING (HYLO TABLES ONLY)	1
48	22017	FLAT HD. SCREW, 1/4-20UNC X 3/4	2
49	20024	BOLT, SOCKET HEAD, 1/4 - 20 UNC X 1 1/4	1
50	57103	BLOCK	1
51	21620	FLAT WASHER 1/4ID X 9/16OD	2
52	50720	SPACER	1
53	21810	FLAT WASHER 3/8ID X 13/16OD	1
54	24160	LOCK KNOB	1
55	55932	LOCK ROD	1
56	21981	PLASTIC FLAT HD. SCREW, #8-32 NC X 1/2	1
57	21420	HEX.NUT, #8-32NC	1
58	22657	ROLL PIN 1/8 X 3/8	1
59	56060	STABILIZER BRACE ASS'Y	1
60	57144	FRONT ROCKER FRAME ASS'Y	1
61	20197	SOCKET HD. SHOULDER BOLT, 5/16-18 UNC	4

FLEXION HEAD CUSHION ASSEMBLY

(617459)

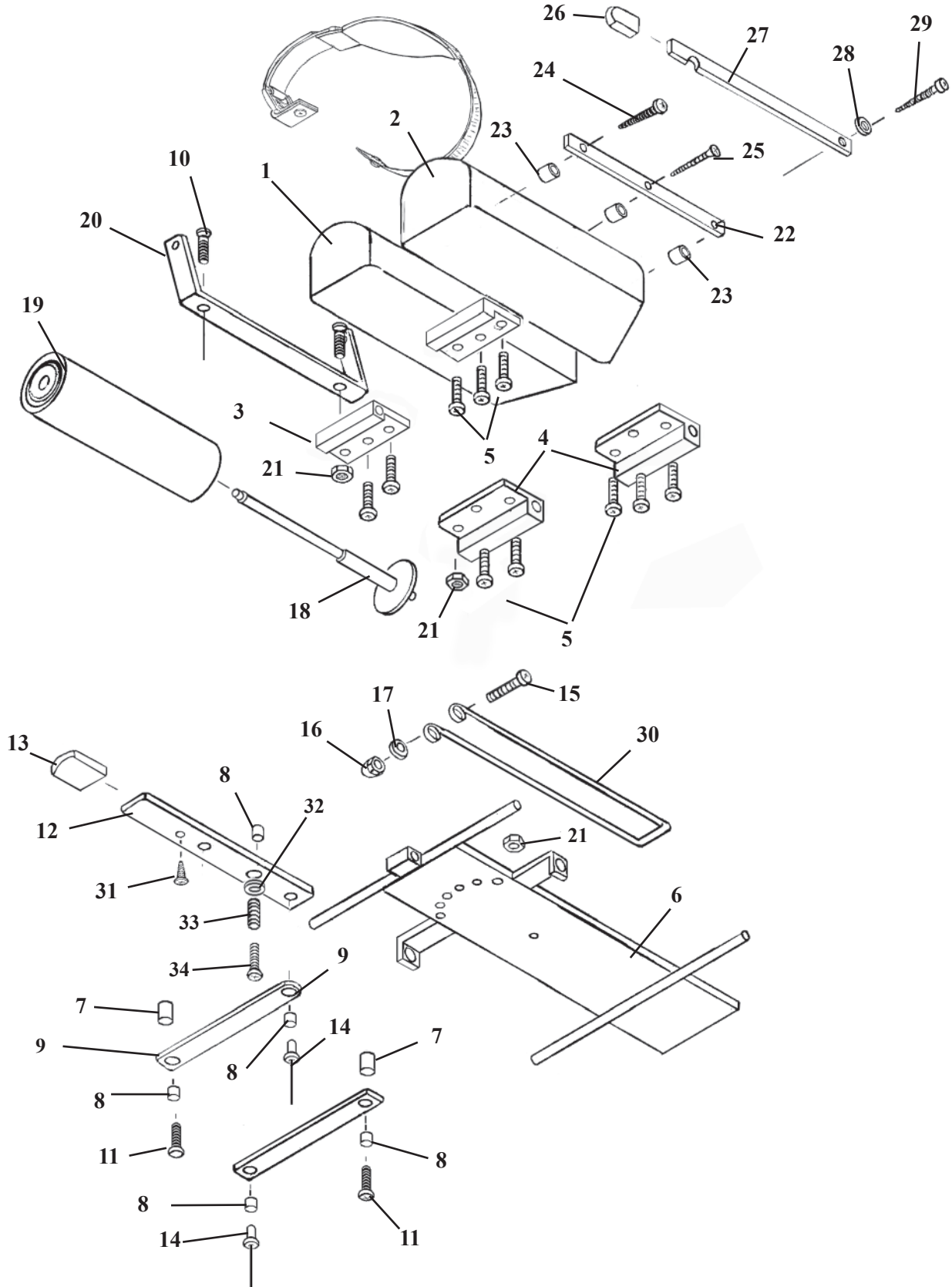

FLEXION HEAD CUSHION ASSEMBLY

ITEM	PART NO.	DESCRIPTION	QTY.
1	40980	HEAD CUSHION ASSEMBLY (RH)	1
2	40979	HEAD CUSHION ASSEMBLY (LH)	1
3	57155	GUIDE BRACKET	2
4	57156	GUIDE BRACKET	2
5	22003	SCREW, MACHINE, PAN HEAD, #10 – 24 UNC X ¾	12
6	55825	INSIDE HEAD FRAME	1
7	57174	SPACER FORWARD DROP 3/8 X 1/2 X 5/8	4
8	22860	BUSHING, 3/16 ID X ¼ OD	5
9	57175	LINKAGE BAR	2
10	21995	SCREW, MACHINE, PAN HEAD, #10 – 24 NC X ½	2
11	22009	SCREW, MACHINE, #10 – 24 UNC X 11/2	2
12	57188	ADJUSTMENT BAR	1
13	24236	PLASTIC CAP	1
14	22695	RIVET, 3/16 X 3/8	2
15	22009	SCREW, MACHINE, PAN HEAD, #10 – 24 UNC X 1 ½	1
16	21447	NUT, ACORN, #10 – 24 UNC	1
17	21510	WASHER, FLAT, 3/16 ID X ½ OD	2
18A	57956	HANGER ASSEMBLY	1
18B	56430	HANGER ASSEMBLY (TILT TABLES ONLY)	1
19	29999	CREPE HEAD REST PAPER	1
20	55841	BRACKET, PAPER HOLDER, FLEX HEAD	1
21	21450	NUT, HEX, #10 – 24 UNC	3
22	50750	INSIDE CUTTING BAR	1
23	50720	SPACER, PAPER CUTTER, 3/8 ID X ½ OD	3
24	22522	SCREW, WOOD, ROUND HEAD, #9 X 2	1
25	22510	SCREW, WOOD, FLAT HEAD, #9 X 1 ½	1
26	24235	GUARD, CUTTING BAR	1
27	50770	OUTSIDE CUTTING BAR	1
28	21610	WASHER, FLAT, PLASTIC, 0.26 ID X ½ OD	1
29	22550	SCREW, WOOD, ROUND HEAD, #14 X 2	1
30	30700	CENTER PAPER WIRE, FLEXION HEAD, 1/8 X 25	1
31	22300	SCREW, MACHINE, #8 – 32 UNC X ¼	1
32	21510	FLAT WASHER, 3/8 ID X 1/2 OD	1
33	30722	SPRING, COMPRESSION	1
34	22001	SCREW, MACHINE, FLAT HD. #10-24 UNC X 1.00	1

FLEXION HEAD SHUTTLE ASS'Y

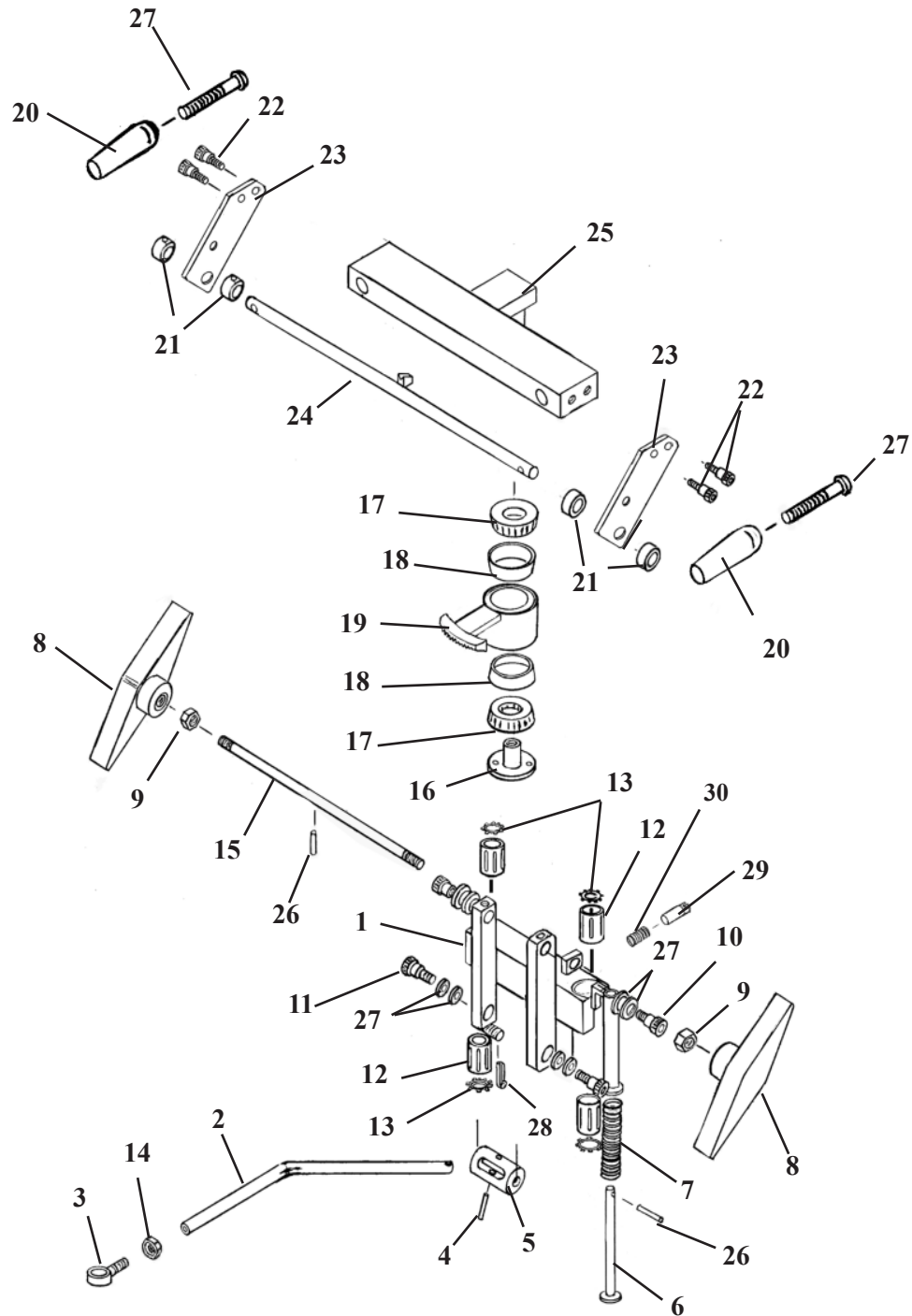

FLEXION HEAD SHUTTLE ASS'Y

ITEM	PART NO.	DESCRIPTION	QTY.
1	55750	SHUTTLE ASS'Y	1
2	55787	LINKAGE ROD	1
3	22740	SWIVAL JOINT END	1
4	22689	SHEARPROOF PIN, ¼ 1 1/4	1
5	55757	ROTATION CYLINDER	1
6	55959	PLUNGER	1
7	30740	COMPRESSION SPRING	1
8	24186	ADJUSTMENT HANDLE	2
9	21210	HEX NUT, 3/8-16 UNC	2
10	20199	SHOULDER BOLT, 5/16-18 UNC X ½	2
11	20003	SHOULDER BOLT, ¼-20 UNC X ½	2
12	22891	GLIDE BEARING	4
13	24050	SNAP RING	4
14	21020	HEX NUT, ¼-28UNF	1
15	55949	ADJUSTMENT ROD	1
16	55764	LOCK COLLAR	1
17	22835	ROLLER BEARING	2
18	22800	RACE, BEARING	2
19	55889	BEARING HUB	1
20	24022	LOCK HANDLE	2
21	22910	COLLAR	4
22	21997	SOCKET SCREW, #10-32 UNC X ½	4
23	55879	SUPPORT PLATE	2
24	55872	LOCK ROD Ass'y	1
25	55768	ROTATION LOCK	1
26	22675	ROLL PIN	1
27	22038	SOCKET HD. MACHINE SCREW, 1/4-20UNC X 2	2
28	22640	COTTER PIN 3/32 X 1	1
29	56007	LOCK PIN	1
30	30750	COMPRESSION SPRING	1

SLIDE FRAME ASS'Y LATERAL FLEXION HEAD

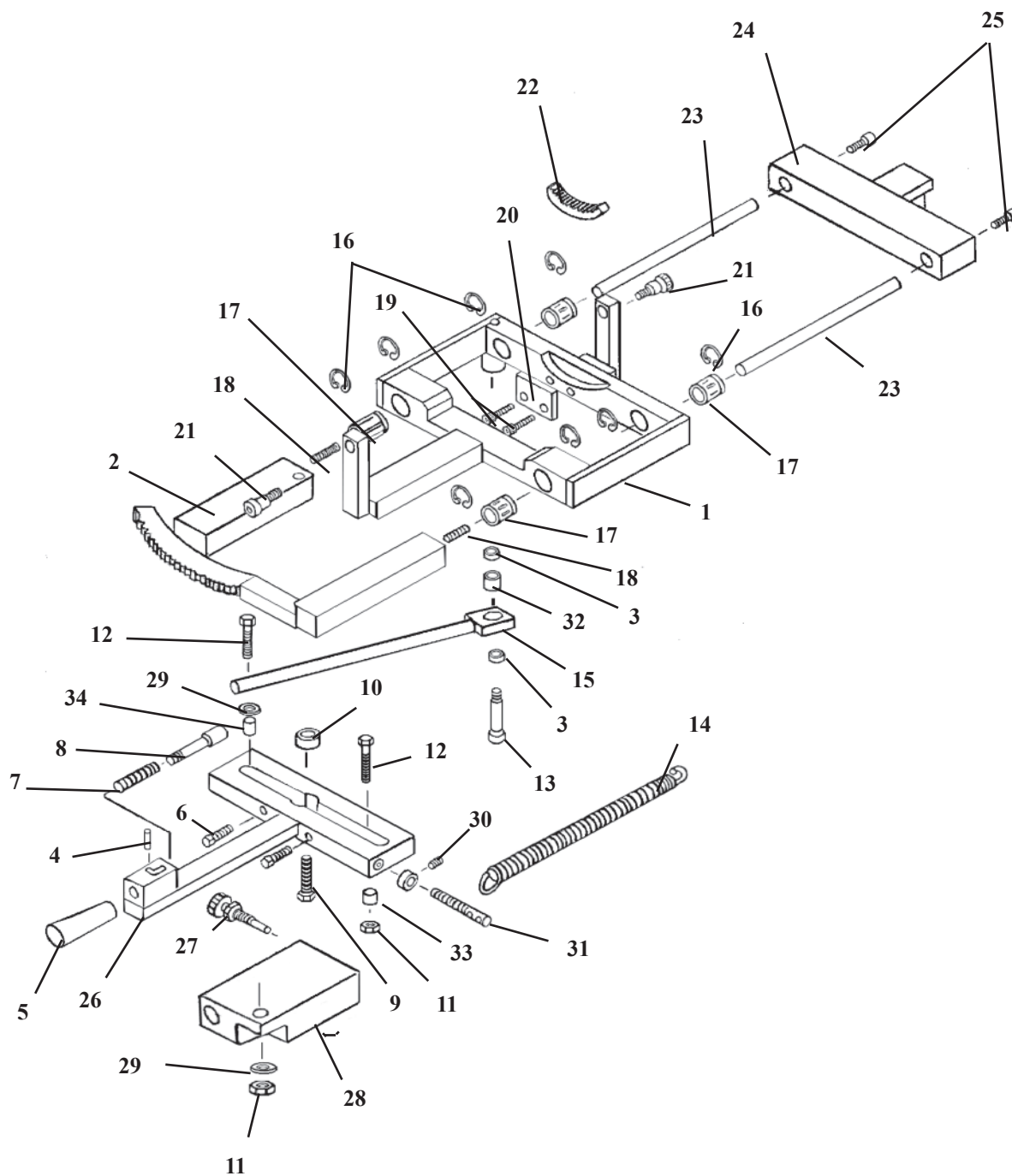

SLIDE FRAME ASS'Y LATERAL FLEXION HEAD

ITEM	PART NO.	DESCRIPTION	QTY.
1	55778	SLIDE BRACKET ASS'Y	1
2	55794	LOCK FRAME ASS'Y	1
3	56006	BUSHING, ¼ ID X 5/16 OD	2
4	22657	ROLL PIN 1/8 X 3/8	1
5	22660	LOCK KNOB	1
6	22031	SOCKET HD SCREW, ¼-20 UNC X 1 ¼	2
7	30750	COMPRESSION SPRING	1
8	55762	LOCK PISTON	1
9	20332	HEX. HD. BOLT 3/8-16 UNC X 1	1
10	22810	ROLL BEARING	1
11	21020	HEX. NUT, ¼-28 UNF	2
12	55813	HEX. HD. BOLT ¼-28 UNF X 1 1/4	2
13	20010	HEX. BOLT, ¼-20 UNC X 3/4	1
14	30777	RETURN SPRING 1/2OD X 3 ½	1
15	55875	LINKAGE BAR	1
16	24287	C-CLIP	8
17	22892	BEARING S6, 3/8ID X 5/8 OD	4
18	55809	STUD, #10-32 UNF X ¾	2
19	22004	SOCKET HD. BOLT, #10-24 UNC X 1	2
20	55957	SUPPORT PLATE	1
21	20199	SOCKET HD. BOLT, 5/16-18 UNC, 3/8 X ½ SHLD.	2
22	56026	RING GEAR	1
23	55763	GUIDE ROD	2
24	55768	SIDE BENDING BLOCK	1
25	21997	SOCKET HD. BOLT, #10-32UNF X ½	2
26	55758	MOTION HANDLE ASS'Y	1
27	20322	LOCK BOLT	1
28	55874	LOCK BLOCK	1
29	21620	FLAT WASHER ¼ ID	2
30	22921	COLLAR	1
31	20258	HEX. HD. BOLT, 5/16-18UNC X 2 ½	1
32	50720	SPACER 3/8 ID X 1/2 OD X 1/2	1
33	22881	OILITE BUSHING 1/4 ID X 3/8 OD X 3/8	1
34	58009	BUSHING 1/4 ID X 7/16 OD X .26	1

FLEXION HEAD ROTATION BLOCK ASSEMBLY

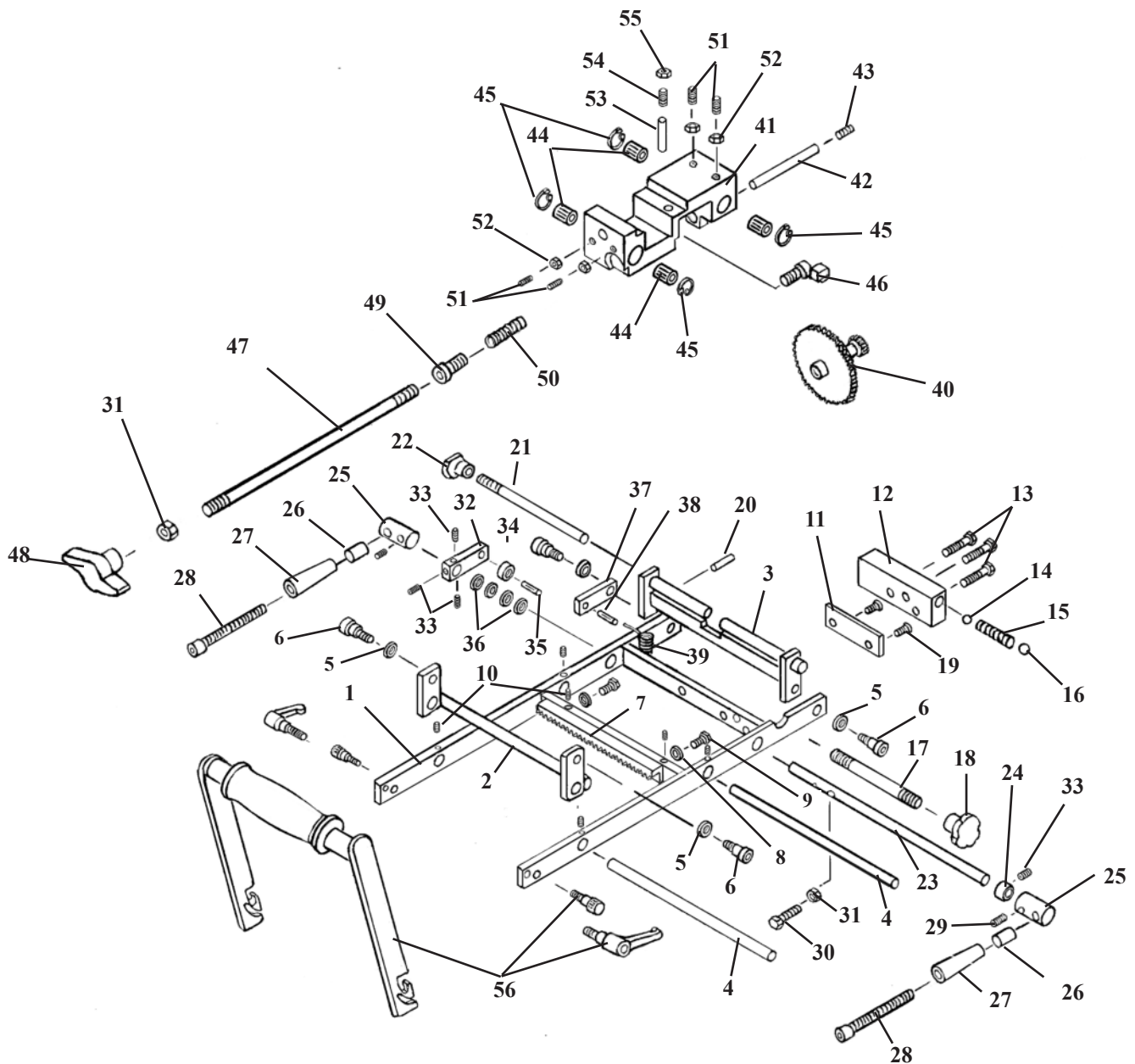

Item 56 - Flexion Handle Kit #634020

Part No.	Description	Qty
55838	Handle Tube	1
55836	Side Ass'y (RH)	1
55837	Side Ass'y (LH)	1
24023	Handle Grip	1
24024	Adjustable Thumb Handle	2
20188	Socket Hd. Bolt #10-24	2
22410	Pan Hd. Screw	2
24060	Buckle, Plastic	1
28108	Harness, Hd, Neoprene	1

FLEXION HEAD ROTATION BLOCK ASSEMBLY

ITEM	PART NO.	DESCRIPTION	QTY.
1	55777	ROTATION FRAME ASSEMBLY, FLEXION HEAD	1
2	55773	PIVOT ARM ASSEMBLY, FLEXION HEAD	1
3	55963	STABILIZER BRACKET ASS'Y, SWIVEL HEAD	1
4	55788	GUIDE ROD, CRADLE ASS'Y, FLEX HD, 3/8 RD X 7 5/8	2
5	21610	WASHER, FLAT PLASTIC, 0.26 ID X 1/2 OD	4
6	20002	BOLT, SOCKET HEAD, 1/4 - 20 UNC SHOULDER 5/6 X 3/8	4
7	55984	GEAR RACK MOUNT ASS'Y, SWIVEL HEAD	1
8	21510	WASHER, FLAT, 3/16 ID X 1/2 OD	2
9	20000	BOLT, HEX HEAD, #10 - 32 UNF X 1/2	2
10	22090	SCREW, SET, #10 - 32 UNF X 3/16	6
11	55815	MOUNTING PLATE, FLEXION HEAD, 1/4 X 1 X 2 3/8	1
12	55789	BLOCK, DROP, FLEXION HEAD, 5/8 X 1 X 2.575	1
13	22001	SCREW, MACHINE, FLAT HEAD, #10 - 24 UNC X 1	3
14	22701	BALL, STEEL, 1/4" DIA	1
15	30721	SPRING, COMPRESSION, 9/64 ID X 1/4 OD X 1 1/4	1
16	22700	BALL, STEEL, 3/8" DIA	1
17	52172	ROD, ADJUSTMENT, 5/16 X 3 1/6	1
18	24150	KNOB, ADJUSTMENT	1
19	22073	SCREW, MACH, FLAT HD, 5/16 - 18 UNC X 7/16-GROUND OFF	2
20	22657	PIN, ROLL, 1/8 X 3/8	1
21	55968	ROD, LOCK	1
22	24160	KNOB, LOCK, STABILIZER, SWIVEL HD, 1/4 RD X 6 1/4	1
23	56032	COCKING ARM ASSEMBLY, SWIVEL HEAD	1
24	22912	COLLAR, 3/8" ID	1
25	56035	COLLAR, COCKING ROD, SWIVEL HD, 3/4 RD X 1 1/4	2
26	52192	HANDLE, EXTENSION, 1/4 ID X 9/16 OD X 1	2
27	24021	HANDLE, YELLOW	2
28	20129	BOLT, SOCKET HD, 1/4 - 20 UNC X 3 1/2	2
29	22250	SCREW, SET, 5/16 - 24 UNF X 1/2	2
30	20022	BOLT, HEX HD, 1/4 - 20 UNC X 1	1
31	21010	NUT, HEX, 1/4 - 20 UNC	2
32	58089	ARM, 3/8 X 5/8 X 2 5/16	1
33	22110	SCREW, SET, 1/4 - 20 UNC X 1/4	4
34	22805	BEARING, BALL, 1/4 ID	1
35	22688	PIN, ROLL, 1/4 X 5/8	1
36	21800	WASHER, FLAT, PLASTIC, 3/8 ID X 5/8 OD X 1/16	4
37	55821	COCKING ARM, FLEXION HEAD ASS'Y, 3/16 X 1/2 X 2	1
38	22660	PIN, ROLL, 1/8 X 5/8	1
39	30725	SPRING, EXTENSION, 1/4 ID X 5/16 OD X 1 1/8 (MODIFIED)	1
40	55814	GEAR TRAIN, ROTATION FRAME ASS'Y, FLEXION HEAD	1
41	30423	CRADLE BLOCK, FLEXION HEAD	1
42	55820	AXLE	1
43	22230	SCREW, SET, 5/16 - 18 UNC X 1/4	1
44	22892	BUSHING, 3/8 ID X 7/8 - SUPER 6	4
45	24048	C - CLIP	4
46	55782	GEAR LOCK	1
47	55824	LOCK ROD	1
48	24163	KNOB, PLASTIC, T - HANDLE	1
49	55823	GUIDE PLUG, FLEXION HEAD ASS'Y	1
50	30732	SPRING, COMPRESSION, 1/4 ID X 1 3/8	1
51	22095	SCREW, SET, #10 - 24 - UNC X 1/2	4
52	21450	NUT, HEX, #10 - 24 UNC	4
53	57178	PIN, ADJUSTMENT, 1/4 RD X 5/8	1
54	22231	SCREW, SET, 5/16 - 18 UNC X 3/4	1
55	21110	NUT, JAM, 5/16 - 18 UNC	1
56	634010	HANDLE ASSEMBLY	1

DROP CHEST & LUMBAR CUSHION

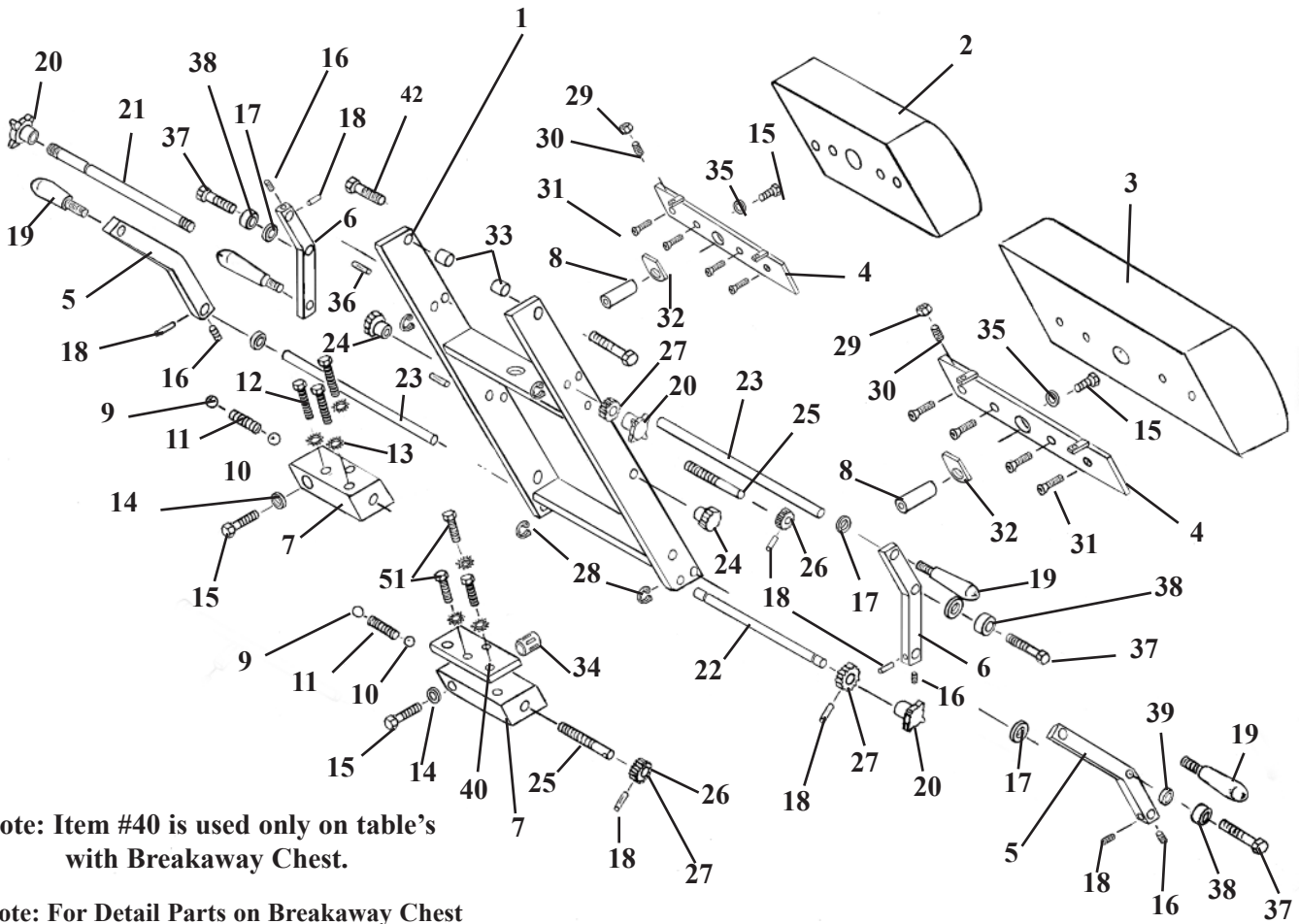

Note: Item #40 is used only on table's with Breakaway Chest.

Note: For Detail Parts on Breakaway Chest refer to Deluxe Chest Cushion (page 22 - 23).

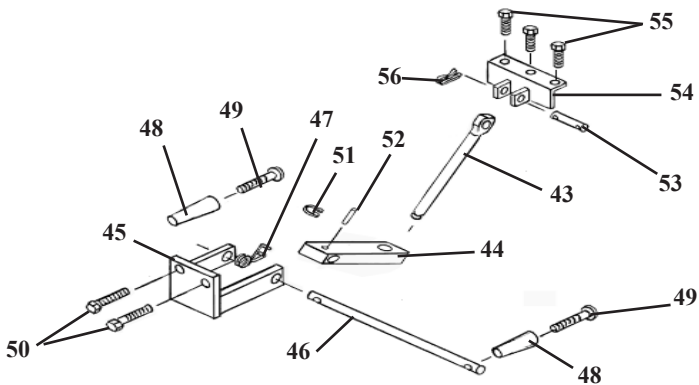

DROP CHEST and LUMBAR ASSEMBLY

ITEM	PART NO.	DESCRIPTION	QTY.
1	57309	CHEST & LUMBAR FRAME ASSEMBLY	1
2	40510	CUSHION, DROP CHEST	1
3	40530	CUSHION, DROP LUMBAR	1
4	57330	MOUNTING PLATE ASS'Y	2
5	57416	COCKING HANDLE BAR (RH)	2
6	57436	COCKING HANDLE BAR (LH)	2
7	30420	DROP BLOCK, ALUMINUM (LH)	2
8	30426	SHAFT, STEEL	2
9	22710	STEEL BALL, 1/2 "	2
10	22700	STEEL BALL, 3/8 "	2
11	30830	COMPRESSION SPRING, 1/4 ID X 1/2 OD X 2	2
12	20250	BOLT, HEX HEAD, 5/16 - 18 UNC X 2	3
13	21755	WASHER, STAR, 5/16 ID X 0.60 OD	6
14	21860	WASHER, FLAT, 7/16 ID X 1 OD	2
15	20321	BOLT, HEX HEAD, 3/8 - 24 UNF X 3/4	4
16	22160	SET SCREW, 1/4 - 28 UNF X 1/4	4
17	21915	WASHER, FLAT, PLASTIC, 9/16 ID X 11/16 OD X 1/16	4
18	22670	ROLL PIN, 1/8 X 3/4	8
19	24012	HANDLE, 3/8 - 16 UNC X 1/2 STUD	4
20	24180	KNOB, TENSION	4
21	52530	ROD, TENSION ADJUSTMENT, 3/8 RD X 12 7/8	1
22	52510	ROD, TENSION ADJUSTMENT, 3/8 RD X 17 3/4	1
23	52350	ROD, COCKING, 1/2 RD X 9 1/4	2
24	24150	KNOB, LOCK	2
25	57440	STUD, 3/8 RD X 2 11/16	2
26	30312	GEAR, PLASTIC, 3/8 ID X 1 1/8 OD X 36 TH	2
27	30310	GEAR, PLASTIC, 3/8 ID X 1 1/2 OD X 5/8	2
28	24290	E-RING, SNAP, 3/8	4
29	21010	NUT, HEX, 1/4 - 20 UNC	4
30	22120	SET SCREW, 1/4 - 20 UNC X 1/2	4
31	22030	SCREW, MACH, FLAT HEAD, 1/4 - 20 UNC X 1	8
32	40730	CUSHION PAD	2
33	57397	BUSHING, 3/8 ID X 1/2 OD X 0.337	2
34	22845	BUSHING, BALL BEARING, 3/4 ID X 1 5/8	2
35	21820	WASHER, LOCK, 3/8 ID	2
36	22685	ROLL PIN, 3/16 X 1	2
37	20320	BOLT, HEX HEAD, 3/8 - 16 UNC X 3/4	4
38	22810	BEARING, 3/8 ID X 13/16 OD	4
39	37928	SPACER, 3/8 ID X 1/2 OD X 3/16	4
40	57342	REINFORCEMENT PLATE, 5/16 X 2 X 4	1
41	20253	BOLT, HEX HEAD, 5/16 - 18 UNC X 2 1/4	3
42	20332	BOLT, HEX HEAD, 3/8 - 16 NC X 1	2
43	57450	EYE-ROD ASS'Y, 9/16 RD X 6 9/16	1
44	54082	BLOCK, DROP CHEST, 3/4 X 1 X 3 5/8	1
45	56203	BRACKET, SUPPORT YOKE, DROP CHEST	1
46	51230	ROD, ADJUSTMENT, DROP BLOCK, 1/2 X 11 1/4	1
47	30870	SPRING, TORSION COIL, 19 GA	1
48	24020	HANDLE, BLACK	2
49	22050	SCREW, MACH, RD HEAD, 1/4 - 20 NC X 2 1/2	2
50	20332	BOLT, HEX HEAD, 3/8 - 16 NC X 1	2
51	24286	SNAP RING, 9/16"	1
52	22660	ROLL PIN, 1/8 X 5/8	1
53	51920	PIN, EYE-ROD, CHEST - LUMBAR, 1/2 RD X 2 3/8	1
54	57319	BRACKET ASS'Y, ATTACHMENT, CHEST-LUMBAR	1
55	20258	BOLT, HEX HEAD, 5/16 - 18 NC X 2 1/2	3
56	22640	COTTER PIN, 3/32 X 1	2

DROP CHEST ASS'Y FULL CUSHION

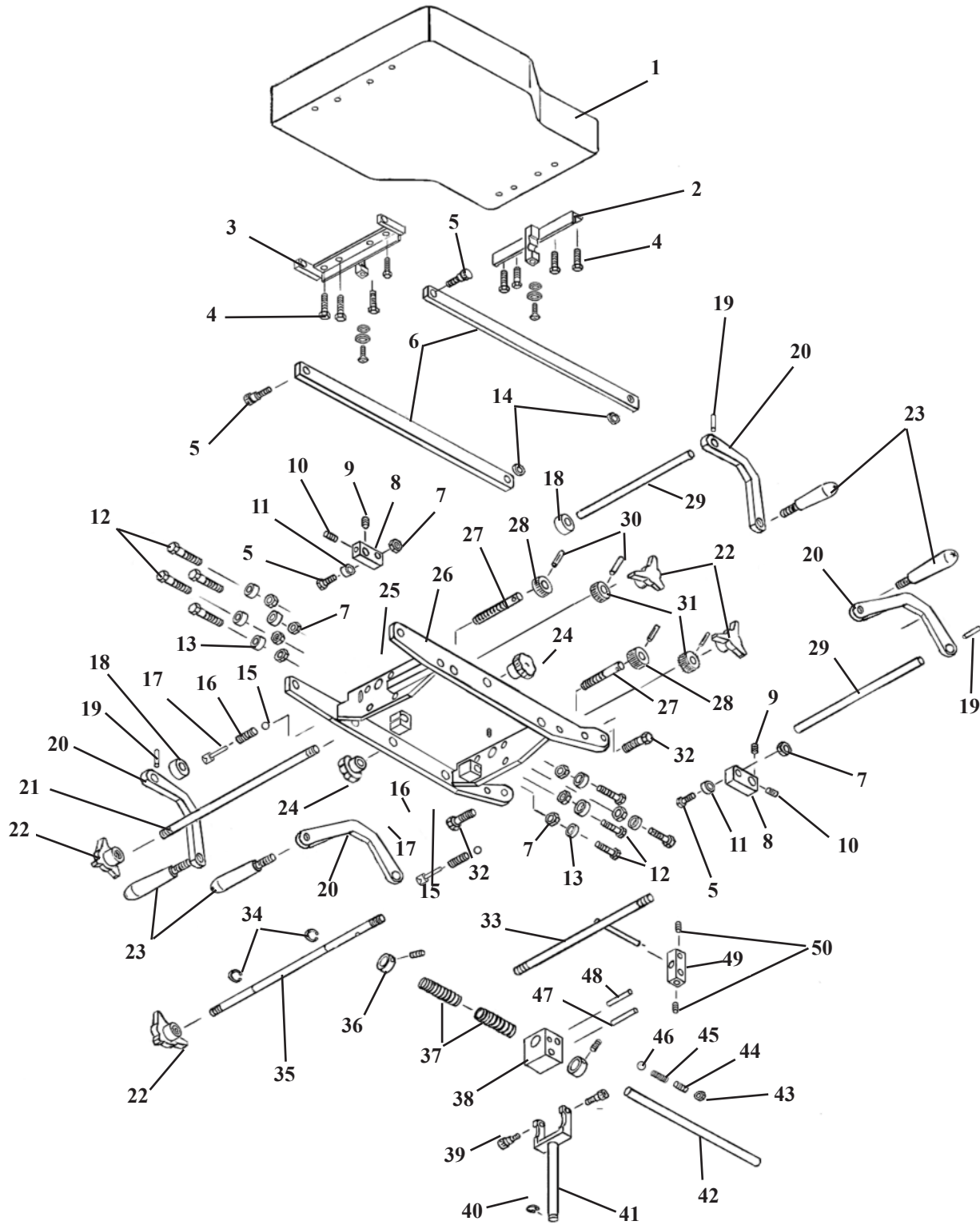

DROP CHEST ASSEMBLY FULL CUSHION

ITEM	PART NO.	DESCRIPTION	QTY.
1	40235	CHEST CUSHION ASSEMBLY	1
2	57428	TEE WEDGE ASSEMBLY, FRONT, NEW DROP	1
3	57429	TEE WEDGE ASSEMBLY, REAR, NEW DROP	1
4	20022	BOLT, HEX HEAD, 1/4 - 20 NC X 1.00	8
5	20332	BOLT, HEX HEAD, 3/8 - 16 NC X 1.00	4
6	57435	BAR, STABILIZER, DROP CHEST, 1/4 X 5/8 X 6 13/16	2
7	21210	NUT, HEX, 3/8 - 16 NC	9
8	52731	ARM, COCKING, 3/4 X 9/16 X 2 5/8	2
9	22260	SET SCREW, 5/16 - 24 NF X 1/4	2
10	22250	SET SCREW, 5/16 - 24 NF X 1/2	2
11	22810	BEARING, ROLLER, 3/8 ID	2
12	20330	BOLT, HEX HEAD, 3/8 - 16 NC X 7/8	8
13	22812	BEARING, ROLLER, 3/8 ID	8
14	21850	WASHER, PLASTIC, 3/8 ID X 1 OD	2
15	22700	BALL, STEEL, 3/8	2
16	30830	SPRING, COMPRESSION, 1/4 ID X 1/2 OD X 2	2
17	22710	BALL, STEEL, 1/2	2
18	22993	COLLAR, SET. 1/2 ID X 1.00 OD	4
19	22670	ROLL PIN, 1/8 X 3/4	4
20	57449	HANDLE, COCKING, NEW DROP	4
21	57447	ROD, TENSION ADJUSTMENT, 3/8 X 17 1/2	1
22	24180	KNOB, TENSION	4
23	24012	HANDLE, GRIP	4
24	24150	KNOB, LOCK	2
25	22160	SET SCREW, 1/4 - 28 NF X 1/4	2
26	57424	DROP CHEST FRAME ASSEMBLY, NEW DROP	1
27	57445	SCREW, TENSION, 3/8 X 3.1	2
28	30312	GEAR, TENSION, PLASTIC, 3/8 ID X 1 1/8 OD X 36 TH	2
29	52350	ROD, COCKING, 1/2 RD X 9	2
30	22673	ROLL PIN, 1/8 X 1	4
31	30310	GEAR, TENSION, PLASTIC, 3/8 ID X 1 1/2 OD X 5/8	2
32	20222	BOLT, HEX HEAD, 3/8 - 16 NC X 1 1/4	2
33	57438	ROD, LOCK	1
34	24290	E-CLIP, 3/8	2
35	57448	ROD, TENSION ADJUSTMENT, NEW DROP, 3/8 X 12 3/4	1
36	22940	COLLAR, 5/8 ID X 1 3/32 OD X 1/2	2
37	30793	SPRING, COMPRESSION, 11/16 ID X 15/16 OD X 3 1/8	2
38	51090	BLOCK, YOKE, 1 X 1 1/2 X 1 11/16, BRKY CHEST	1
39	20197	BOLT, SOCKET HD, 5/16 - 18 NC, SHOU 3/8 X 3/8	2
40	24286	SNAP RING, 9/16	1
41	56190	FORK ASSEMBLY, CHEST	1
42	57346	ROD, SPRING SUPPORT, 5/8 RD X 6 31/32	1
43	21012	NUT, HEX, 1/4 - 20 NC	1
44	22120	SET SCREW, 1/4 - 20 NC X 1/2	1
45	30715	SPRING, COMPRESSION, 3/16 ID X 0.140 OD X 3/8	1
46	22702	BALL, STEEL, 3/16	1
47	57345	PIN, SLIDE, LOCKING ASS'Y, 5/16 X 3	1
48	57344	PIN, LOCKING, 1/4 RD X 2 1/8	1
49	57343	BLOCK, DROP, LOCKING, 1/2 X 1/2 X 1 9/16	1
50	22160	SET SCREW, 1/4 - 28 NF X 1/4	2

T-PELVIC ASSEMBLY NON-ROTATION

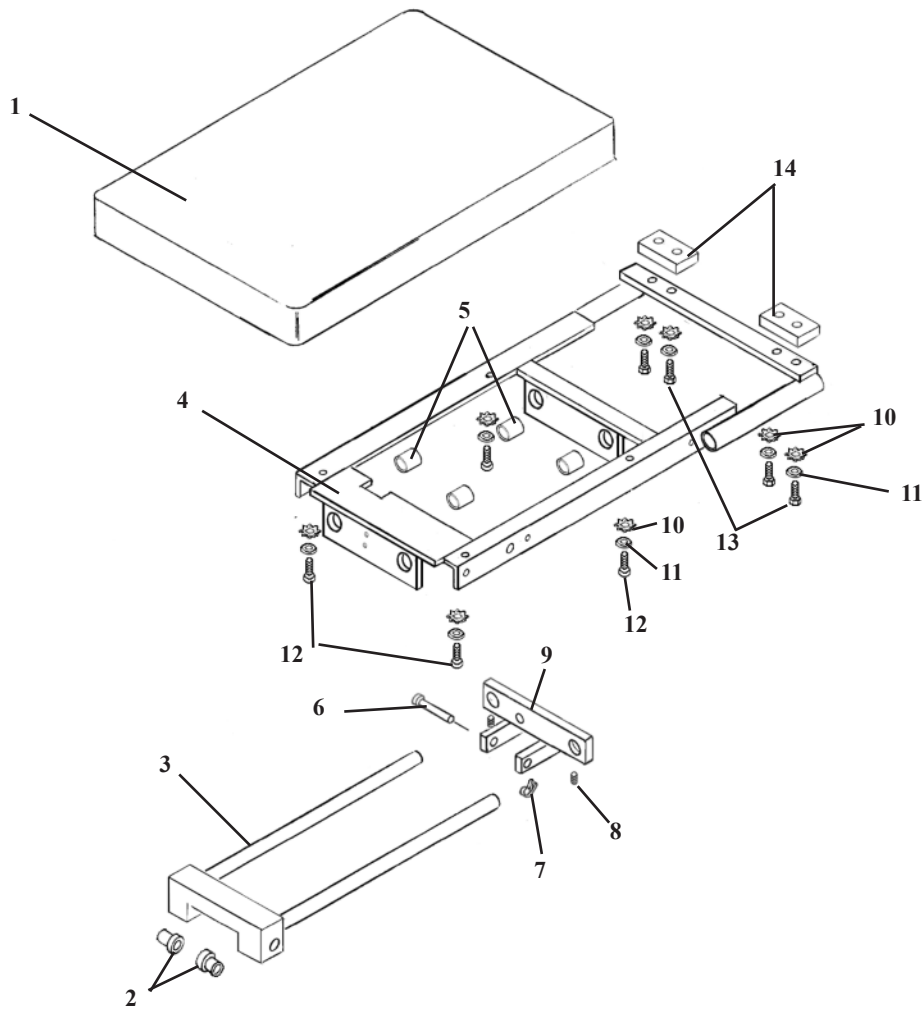

ITEM	PART NO.	DESCRIPTION	QTY.
1	40292	PELVIC CUSHION ASS'Y	1
2	22888	CAP BUSHING, BRASS	2
3	58542	GUIDE FRAME ASS'Y	1
4	58527	CARRIAGE FRAME ASS'Y	1
5	22850	BUSHING, NYLON, 3/4 ID X 7/8 OD X 3/4	4
6	22615	CLEVIS PIN, 5/16 X 2	1
7	22639	COTTER PIN, 3/32 X 1/2	1
8	22250	SET SCREW, 5/16-24 UNF X 1/2	3
9	58594	SLIDE BRACKET ASS'Y	1
10	21620	WASHER, FLAT, 1/4 ID X 9/16 OD	8
11	21630	STAR WASHER, 1/4 ID	8
12	20021	BOLT, SOCKET HD. 1/4-20 UNC X 1	4
13	20023	BOLT, HEX HD. 1/4-20 UNC X 1 1/4	4
14	53264	SPACER, 3/8 X 1 1/4 X 2 3/8	2

T-BAR ASS'Y

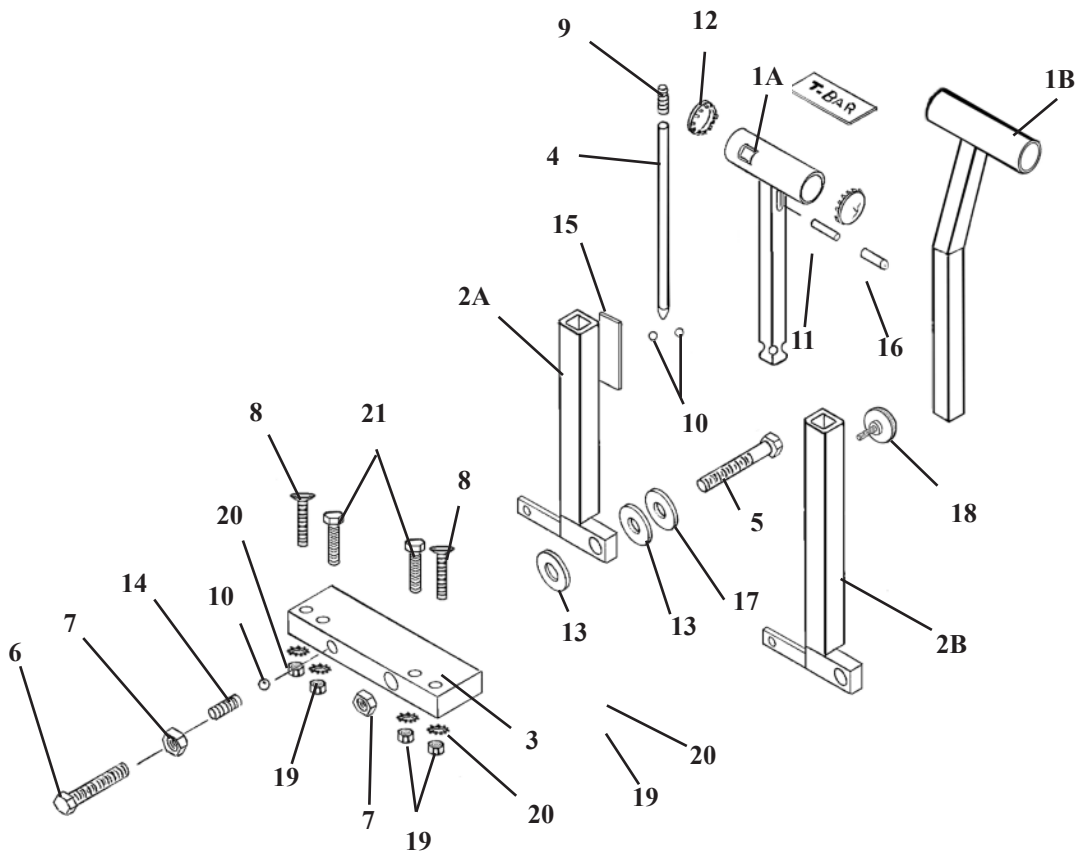

ITEM	PART N0.	DESCRIPTION	QTY.
1A	58406	T-HANDLE, (SHORT)	1
1B	58405	T-HANDLE, (LONG)	1
2A	58400	GUIDE TUBE, (SHORT)	1
2B	58398	GUIDE TUBE, (LONG)	1
3	58411	MOUNTING BLOCK	1
4	58405	LOCK ROD	1
5	20507	HEX HD. BOLT, 7/16-14 UNC X 3 1/4	1
6	20503	HEX HD. BOLT, 7/16-14 UNC X 1 1/4	1
7	21290	HEX NUT, 7/16-14 UNC	2
8	22036	SOCKET HD. MACHINE SCREW, 1/-20 UNC X 1 1/4	2
9	30732	COMPRESSION SPRING, 1/4 ID X 1 3/8	1
10	22700	STEEL BALL, 3/8	2
11	52190	COCKING PEG, 1/4 RD. X 1 3/4	1
12	24413	CAP	2
13	21912	FLAT WASHER, PLASTIC, 1/2 ID X 1 1/4 OD	2
14	30721	COMPRESSION SPRING	1
15	31160	STICKER	1
16	24415	END CAP	2
17	21910	FLAT WASHER, 1/2 ID X 1 OD	1
18	24181	LOCK KNOB	1
19	21010	HEX NUT, 1/4-20 UNC	2
20	21630	STAR WASHER, 1/4 ID	2
21	20027	HEX HD. BOLT, 1/4-20 UNC X 1 1/2	2

T-DROP PELVIC ASS'Y NON-ROTATION

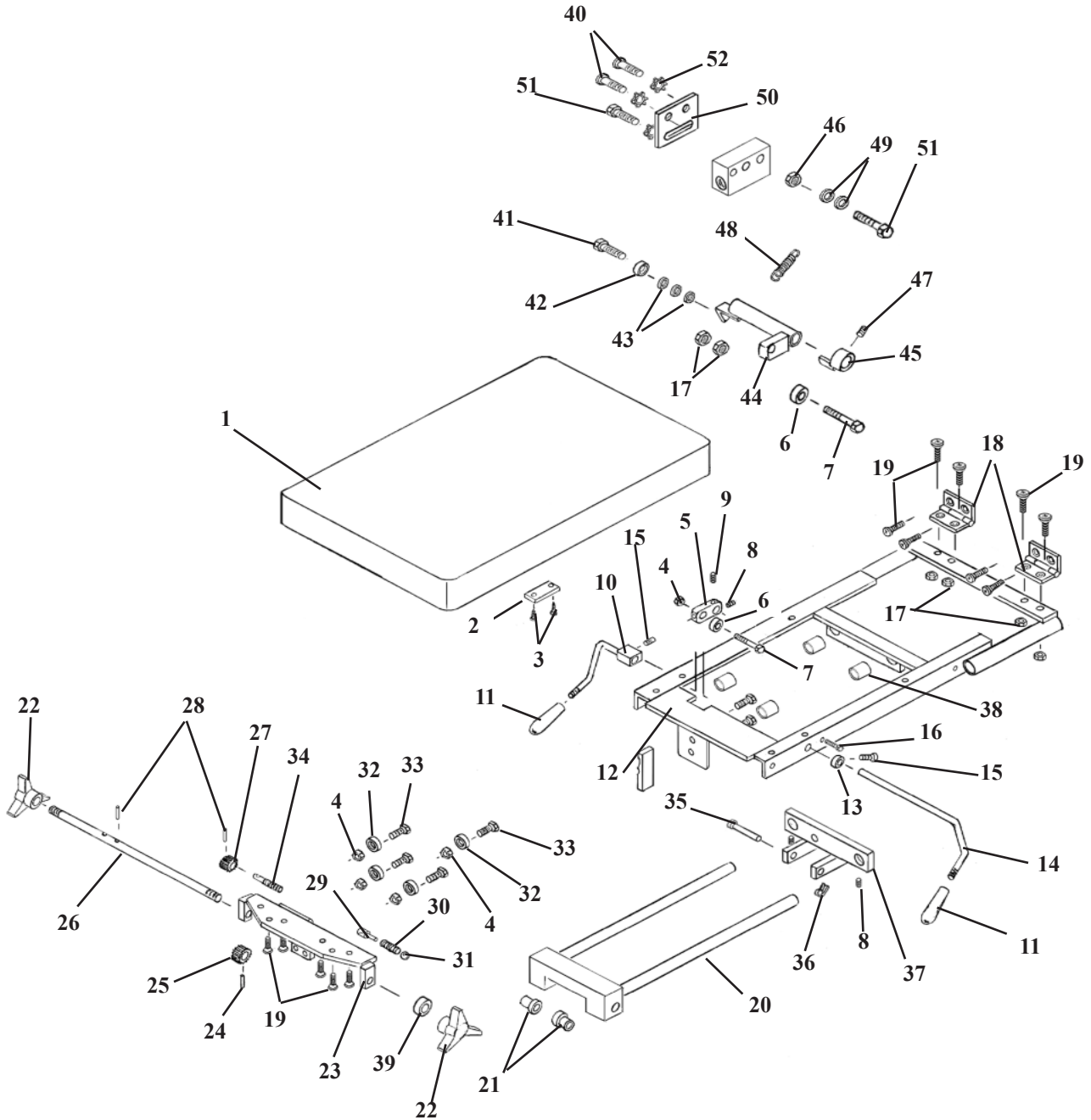

T-DROP PELVIC ASS'Y NON- ROTATION

ITEM	PART NO.	DESCRIPTION	QTY.
1	40307	PELVIC CUSHION ASS'Y	1
2	56493	STRIKER PLATE	1
3	22469	FLAT HD WOOD SCREW, #10 X 7/8	2
4	21210	HEX NUT, 3/8-16UNC	5
5	56359	COCKING ARM	1
6	22810	ROLLER BEARING	1
7	20350	HEX HD BOLT, 3/8-16UNC X 1 3/4	1
8	22250	SET SCREW, 5/16-24UNF X 1/2	3
9	22260	SET SCREW, 5/16-24UNF X 1/4	1
10	56565	COCKING HANDLE ASS'Y	1
11	22660	PLASTIC HANDLE	2
12	58527	CARRIAGE FRAME ASS'Y	1
13	22930	COLLAR 7/16ID	1
14	56378	COCKING HANDLE	1
15	22120	SET SCREW,, 1/4-20UNC X 1/2	1
16	20010	HEX HD BOTL, 1/4-20UNC X 3/4	1
17	21010	HEX NUT, 1/4-20UNC	2
18	58181	HING, 2X2	2
19	22030	FLAT HD SCREW, 1/4-20UNC X 1.00	14
20	58542	GUIDE FRAME ASS'Y	1
21	22888	BRASS CAP BUSHING	2
22	24180	TENSION KNOB	2
23	58547	BEARING PLATE ASS'Y	1
24	22670	ROLL PIN, 1/8 X 3/4	1
25	30312	PLASTIC GEAR, 3/8ID X 1 1/8OD X 36 TH	1
26	58596	TENISON ROD, 3/8RD X 21	1
27	30311	PLASTIC GEAR, 3/8RD X 15/16OD X 28 TH	1
28	22660	ROLL PIN, 1/8 X 5/8	1
29	22700	STEEL BALL, 3/8 DIA	1
30	30710	COMPRESSION SPRING	1
31	22710	STEEL BALL, 1/2 DIA	1
32	22812	BALL BEARING, 3/8ID	4
33	20332	HEX HD BOLT, 3/8-16UNC X 1	4
34	56332	TENSION SCREW	1
35	22615	CLEVIS PIN, 5/16 X 2	1
36	22639	COTTER PIN, 3/32 X 1/2	1
37	58594	SLIDE BRACKET ASS'Y	1
38	22850	BUSHING NYLON 3/4 ID X 7/8 OD X 3/4	4
39	22912	SET COLLAR, 3/8 ID	1

OPTIONAL AUTO COCKING PARTS

40	22030	SCREW, MACHINE, FLAT HD, /4-20 X 1.00	2
41	20022	HEX HD, BOLT, 1/4-20UNC X 1.00	1
42	22805	ROLLER BEARING, 1/4ID	1
43	21620	WASHER, FLATE, 1/4ID X 9/16OD	3
44	58582	TRANSFER AXIAL ASSEMBLY	1
45	58559	COCKING COLLAR ASS'Y	1
46	21010	HEX NUT 1/4-20UNC	1
47	22110	SET SCREW, 1/4-20UNC X 1/4	1
48	30725	TENSION SPRING, 1/4 ID X 1 5/16	1
49	21610	WASHER, PLASTIC, 1/4 ID	2
50	58595	MOUNTING PLATE	1
51	20120	HEX HD. BOLT, 1/4-28UNF X 1.00	3
52	21630	STAR WASHER, 1/4ID	4

T-DROP ROTATION PELVIC ASSEMBLY

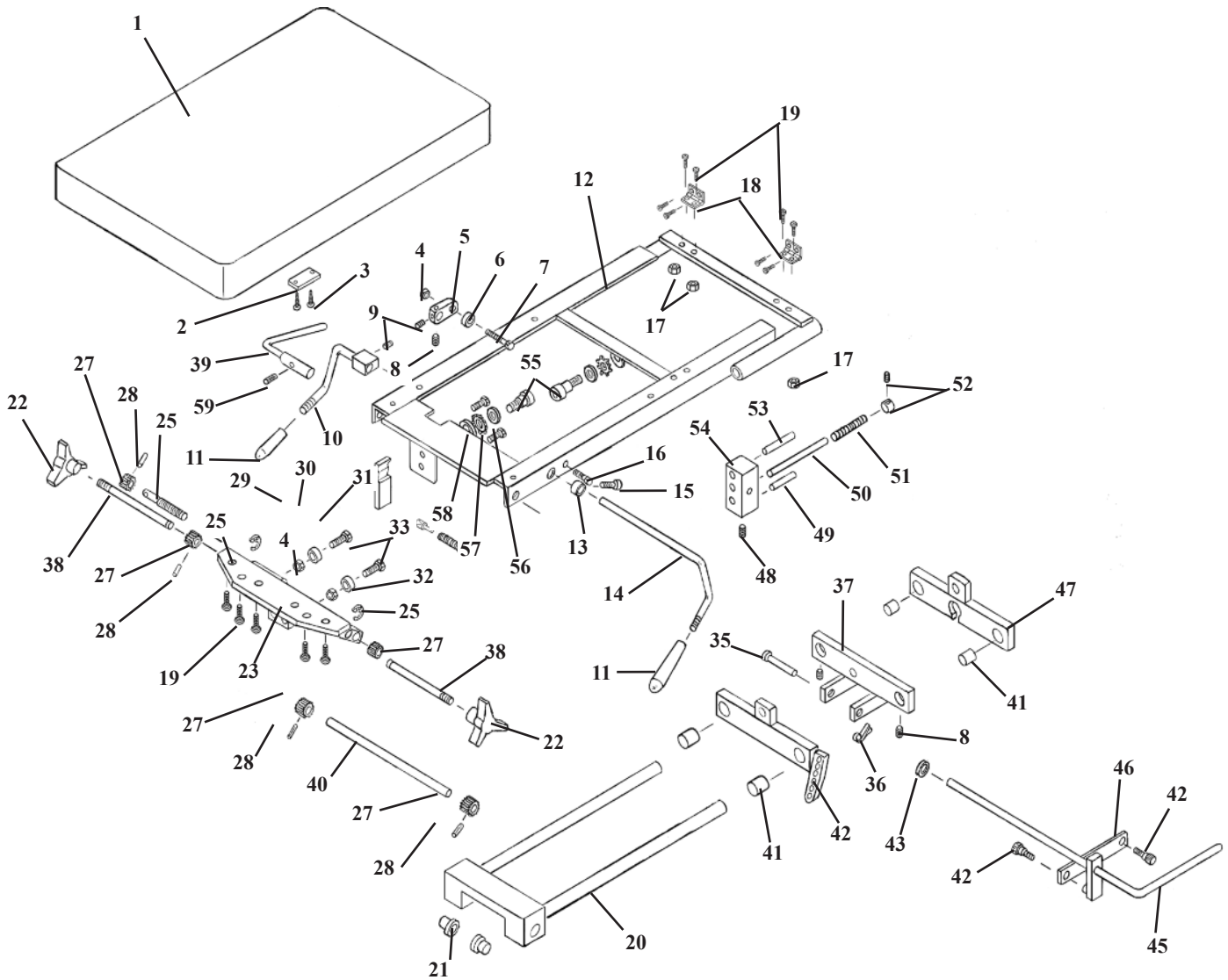

T-DROP & ROTATION PELVIC ASSEMBLY

ITEM	PART NO.	DESCRIPTION	QTY.
1	40307	PELVIC CUSHION ASSEMBLY	1
2	56493	STRIKER PLATE	1
3	22469	FLAT HD WOOD SCREW, #10 X 7/8	2
4	21210	HEX NUT, 3/8-16UNC	5
5	56359	COCKING ARM	1
6	22810	ROLLER BEARING	1
7	20350	HEX HD BOLT, 3/8-16UNC X 1 3/4	1
8	22250	SET SCREW, 5/16-24UNF X 1/2	2
9	22260	SET SCREW, 5/16-24UNF X 1/4	1
10	56565	COCKING HANDLE ASS'Y	1
11	24010	PLASTIC HANDLE	2
12	58526	CARRIAGE FRAME ASS'Y	1
13	22930	COLLAR 7/16ID	1
14	56378	COCKING HANDLE	1
15	22120	SET SCREW, 1/4-20UNC X 1/2	1
16	20010	HEX HD BOLT, 1/4-20UNC X 3/4	1
17	21010	HEX NUT, 1/4-20UNC	4
18	58181	HING, 2X2	2
19	22030	FLAT HD SCREW, 1/4-20UNC X 1.00	14
20	58542	GUIDE FRAME ASS'Y	1
21	22888	BRASS CAP BUSHING	2
22	24180	TENSION KNOB	2
23	58540	BEARING PLATE ASS'Y	1
24	22670	ROLL PIN, 1/8 DIA. X 3/4	1
25	24042	SNAP RING, 3/8	2
26	58596	TENISON ROD, 3/8 RD X 21	1
27	30311	PLASTIC GEAR, 3/8 ID X 15/16 OD X 28 TH	4
28	22660	ROLL PIN, 1/8 X 5/8	4
29	22700	STEEL BALL, 3/8 DIA.	1
30	30710	COMPRESSION SPRING	1
31	22710	STEEL BALL, 1/2 DIA.	1
32	22812	BALL BEARING, 3/8 ID	4
33	20332	HEX HD BOLT, 3/8-16UNC X 1	4
34	56332	TENSION SCREW	1
35	22615	CLEVIS PIN, 5/16 X 2	1
36	22639	COTTER PIN, 3/32 DIA. X 1/2	1
37	58594	SLIDE BRACKET ASS'Y	1
38	58586	TENSION ROD, 3/8RD X 5 7/8	2
39	53273	CONTROL HANDLE ASS'Y	1
40	58587	JACK SHAFT, 3/8 X 10 1/4	1
41	22850	BUSHING, 3/4 ID X 7/8 OD	4
42	58543	ROTATION BLOCK ASS'Y	1
43	21760	WASHER, FLAT, 5/16 ID X 1/2 OD	1
44	21997	SOCKET HD BOLT, #10-32UNF X 1/2	2
45	53271	LOCK HANDLE ASS'Y	1
46	53265	LINKAGE BAR, 1/8 X 1/2 X 2 7/16	1
47	58541	CYLINDER BLOCK, ASS'Y	1
48	22160	SET SCREW, 1/4-28UNF X 1/4	1
49	53268	GUIDE PIN, 1/4 RD X 1 3/4	1
50	53267	LOCK PIN, 1/4 RD X 3 1/2	1
51	30751	COMPRESSION SPRING, .29 ID X .37 OD X 2.00	1
52	22910	COLLAR, 1/4 ID	1
53	22687	PIN, TAPER #3	1
54	58590	LOCK BLOCK	1
55	20208	BOLT, SOCKET HD. 1/2-13UNC X 5/8	2
56	24283	SHIM	2
57	24050	WASHER, STAR, 5/8 ID	2
58	21944	WASHER, FLAT, 5/8 ID	2
59	22098	SET SCREW, #10-32UNF	1

LLOYD TABLE COMPANY

PRODUCTS & ACCESSORIES



LLOYD



TABLE COMPANY

102-122 W. Main Street • Lisbon, Iowa 52253-0899 • Phone 319-455-2110
Call Toll Free 1-800-553-7297

FAX: 319-455-2166

www.lloydtable.com

