

LLOYD TABLE COMPANY

702 ELEVATION OPERATION & PARTS MANUAL



Lloyd Table Company
102 W. Main Street * Lisbon, IA 52253
Phone 319-455-2110 Fax 319-455-2166
Website www.lloydtable.com
Email sales@lloydtable.com
Call Toll Free 1-800-553-7297

LLOYD
TABLE COMPANY

CONTENTS

<u>OPERATIONS</u>	<u>PAGE</u>	<u>PARTS / ASSEMBLY</u>	<u>PAGE</u>
Safety and Maintenance.....	1 - 2	I-Frame Assembly, Deluxe, FD, & Flx HD..	22
Head Rest Cushion.....	3 - 8	Adjustable Chest Cushion.....	23
Chest Cushion.....	9	Deluxe Chest Spring Breakaway.....	24
Pelvic Height Adjustment.....	10	Adjustable Pelvic Cushion.....	25
Ankle Rest.....	11	Ankle Rest Assembly.....	26
Power Swith & Fuse Holder	12	Adjustable Height Ankle Rest.....	27
Foot Pedal Control	12	Hydraulics Assembly.....	28
Electronic Height Adjustment (EHA).....	13 - 14	Hydraulics Auto Drops.....	29
Manual & Automatic Drops.....	15- 16	Electrical.....	30
		Electrical - EHA & Auto Drops.....	31-32
		Straight Drop Head.....	33-34
		Forward Motion Drop Head.....	35-36
		CBP Tilt Chest.....	37-38
		CBP Drop Chest.....	30-40
		Drop Chest.....	41-42
		Drop Pelvic.....	43-44
 <u>PARTS / ASSEMBLY</u>	 <u>PAGE</u>		
Stationary Frame.....	17		
Elevation Frame.....	18		
Tilt Head Cushions.....	19		
Deluxe Head Cushions.....	20		
Deluxe Head Frame Assembly.....	21		

Table Serial Number _____

WELCOME!!

Lloyd Table Company, a proud supporter of today's chiropractors, has established the finest line of chiropractic tables in the world. Table products unique in versatility and function, designed to meet your needs.



Concerned for a safe working and treatment environment, Lloyd Table Company asks that you follow the safety tips below.

- * Be aware of **Caution** and **Warning** labels posted throughout the table before operating any functions.
- * Everyone operating the table needs to read the manual and familiarize themselves with all its functions before operating the table with patient on it.
- * A patient should never be unattended, when lying on the table. **NEVER LEAVE A PATIENT ON THE TABLE UNATTENDED!**
- * The patient should be positioned at or near the center of the table with **arms on the armrest cushions.**
- * There should be no more than one operator at the controls.
- * Check the tension on all drops before adjusting the patient. (See Page 7)



MAINTENANCE

The following steps should be performed on a regular basis to maintain your Lloyd table in a smooth operating condition and to assure its long life and top quality appearance.

- * An initial inspection and periodic future inspections should be made to insure that nuts and bolts have not loosened in shipping or during daily operations.
- * Your Lloyd table should be lubricated every **six months**. Parts to be lubricated are all pivot points, and metal to metal sliding mechanisms.
(DO NOT LUBRICATE FRICTION LOCKS)
- * The cushions should be cleaned daily with a mild soap & warm water solution to remove body oils. Rinsed & dried
- * Chrome parts should be cleaned on a weekly basis for appearance.
- * The hydraulic fluid recommended for the pump, is a lubriplate HO1 hydraulic oil, and
- * Perform periodic inspections for oil leaks or drips.

The following sections provide explanations on the operation of your Lloyd table. All references to right and left, will be in relationship to your view, as you face table from the foot end. All references to the front will refer to the head end of the table. Those to the rear will refer to the foot end.

Head Cushion

The head cushion is designed to provide a multitude of positions & operations through our Add On Paper (AOP), Deluxe Headpiece and optional Total Dimension Flexion™ Headpieces.



Tilting Head Adjustment

To raise the tilting headpiece:

1. Lift on the bottom front edges of the cushion.
2. Release when desired height is obtained, the cushion will automatically lock into position.

To lower the tilting headpiece:

1. Support the corner edge of the cushion.
2. Lift the Locking Handle (#1) to release.
3. Gently lower the cushion to the desired height.
4. Release the Lock Handle (#1) and then the cushion to lock.

Deluxe Headpiece

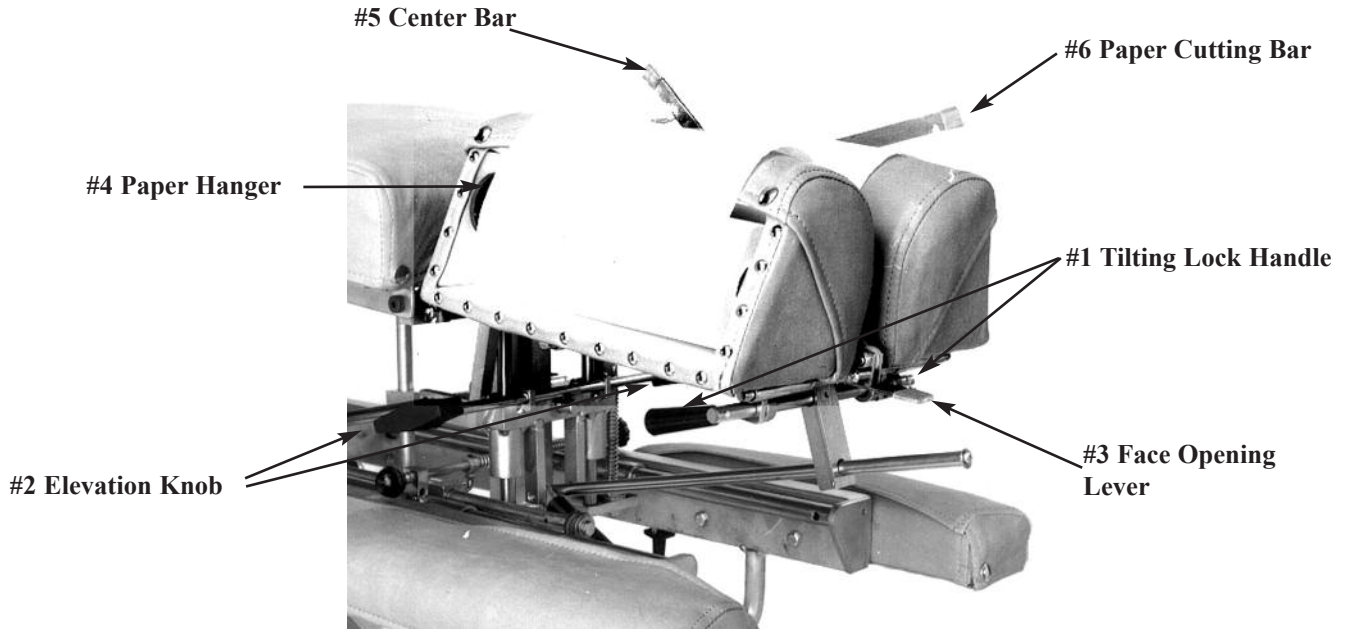

To Raise the tilting feature on the Deluxe Headpiece:

1. Lift on the bottom front edges of the cushion
2. Release at the desired height, the cushion will automatically lock into position.



To Lower the tilting feature on the Deluxe Headpiece:

1. Support the front corner edge of the cushion.
2. Lift the Locking Handle (No. 1) to release
3. Gently lower the cushion to the desired height.
4. Release the lock handle first and then the cushion to lock.



WARNING: TO AVOID INJURIES WHEN RAISING OR LOWERING HEAD CUSHIONS, BE SURE TO HAVE A PROPER HOLD ON THE CUSHION BEFORE RELEASING THE ELEVATING HANDLE (NO. 2).

Deluxe Headpiece

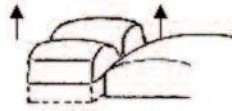

To Elevate the Head Cushion

1. The head cushion is assisted by a gas shock in raising the cushion. With a hand supporting the head cushion, turn the Elevation Knob (No. 2) on either side of the table upward to unlock. When the desired height is determined simply release the Elevation Knob (No. 2) to lock.

To Lower the Head Cushion

1. Turn the Elevation Knob upward to unlock. While unlocked push down on the cushion to lower. When the desired height is determined simply rotate the Elevation Knob (No. 2) down to lock.

Face Opening Adjustment

1. The Head Cushion's face opening can be opened or closed to adjust for comfort with the Face Opening Lever (No. 3). By Pushing slightly down on the Face Opening Lever, slide cushions to adjust opening. The Face Opening Lever must be released in one of eight positions to lock the cushions in place.

Paper Roll

The paper roll mounts conveniently inside the right-hand cushion.

Replacing the Paper Roll

1. Remove the paper hanger tension rod (No. 4) by compressing ends of the rod horizontally. This will allow you to slide one end out, to remove the paper roll tube.
2. Slide a new paper roll on the tension rod so that it rolls off the bottom side. Compress the rod ends horizontally and set inside the head cushion.
3. Swing the Center Bar (No. 5, Page 4) and Outside Cutting Bar (No. 6, Page 4) up. Route paper over the cushions and down between the two outside cutting bars. Return both bars to their original position.
4. Trim the paper by supporting the paper cutting bar with one hand and pulling the paper up along the bar's edge.

Deluxe Head with Drops

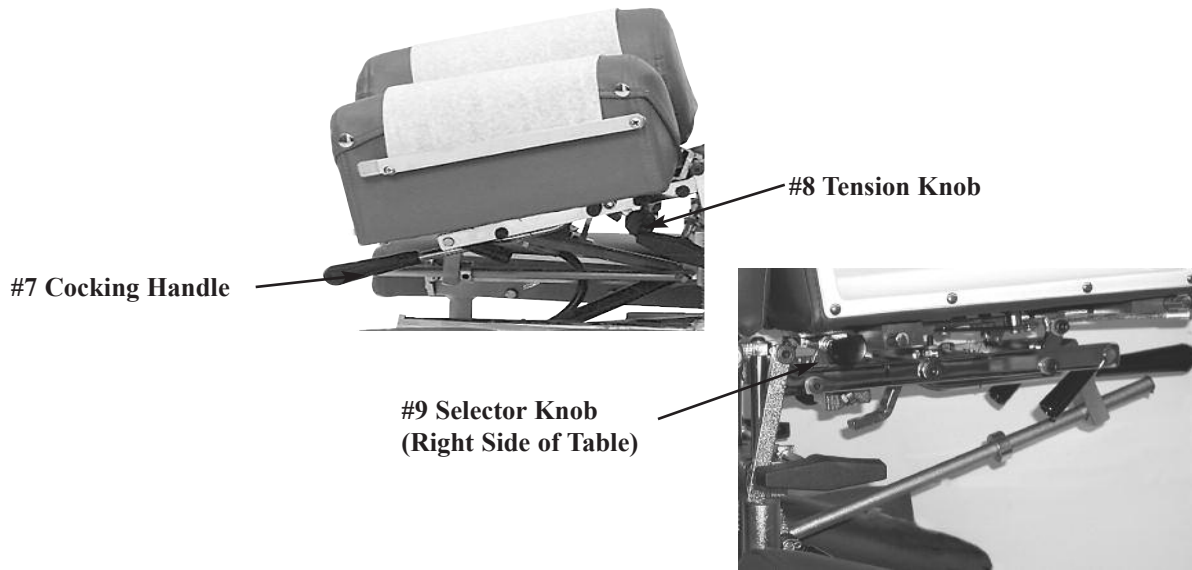

Operating the Straight / Toggle Drop:



CAUTION: THE DROP CUSHION TENSION SHOULD BE CHECKED AND TESTED BEFORE ADJUSTING A PATIENT.

NOTE - DROP SHOULD BE IN DOWN / DEACTIVATED POSITION BEFORE MOVING SELECTOR KNOB (NO. 9) IN OR OUT.

1. To engage the Straight / Toggle Drop head, pull the selector knob (No. 9) out about half an inch.
2. Push down on the Cocking Handle (No. 7) until the head cushion toggle drop is activated .
3. Once cocked, test the drop by pushing down on the cushion. If the cushion drops easily or too hard, adjust the tension with the Tension Knob (No. 8).

Operating The Tension Knob:

1. The tension is adjusted by turning the tension knob (No. 8) in a clockwise and counterclockwise direction.
 - A. Clockwise - Increases tension
 - B. Counterclockwise - Decreases tension

Operating the Forward Motion Drop:



CAUTION: THE DROP CUSHION TENSION SHOULD BE CHECKED AND TESTED BEFORE ADJUSTING A PATIENT.

NOTE - DROP SHOULD BE IN DOWN / DEACTIVATED POSITION BEFORE MOVING SELECTOR KNOB (NO. 9) IN OR OUT.

1. The Selector Knob (No. 9) is to be pushed in, to engage the forward motion drop.
2. Push down on the Cocking Handle (No. 7) until the head cushion forward motion drop is activated.
3. Once cocked, test the drop by pushing down on the cushion, and adjust the tension.

Optional - Total Dimension Flexion Head™

Right Side



Forward & Straight / Toggle Drop Operation Instructions



CAUTION: THE DROP CUSHION TENSION SHOULD BE CHECKED AND TESTED BEFORE ADJUSTING A PATIENT.

NOTE - DROP SHOULD BE IN DOWN / DEACTIVATED POSITION BEFORE MOVING SELECTOR KNOB (NO. 1) IN OR OUT.

1. To engage the Straight / Toggle Drop head, pull the selector knob (No. 1) out about half an inch.
2. Push down on the Cocking Handle (No. 2) until the head cushion is cocked into its top position.
3. Once cocked, test the drop by pushing down on the cushion. If the cushion drops too easily or too hard, adjust the tension with the Tension Knob (No. 9).

Operating The Tension Knob:

1. The tension is adjusted by turning the tension knob (No. 9) in a clockwise and counterclockwise direction.
 - A. Clockwise - Increases tension
 - B. Counterclockwise - Decreases tension



Operating the Forward Motion Drop:

1. The Selector Knob (No. 1) is to be pushed in, to engage the forward motion drop.
2. Push down on the Cocking Handle (No. 2) to raise the drop cushion to its cocked position.
3. Once cocked, test the drop by pushing down on the cushion. If the cushion drops too easily or too hard, adjust the tension with the Tension Knob (No. 9).

Left Side

Optional - Total Dimension Flexion Head™

WARNING: THE FOLLOWING CERVICAL OPERATIONS ARE ONLY TO BE OPERATED BY A PROFESSIONAL PRACTITIONER, EDUCATED IN THE PROCEDURE OF FLEXION-DISTRACTION AND TRACTION, ON THE SPINE.

Lateral Side Bending

1. To unlock the Lateral Side Bending Feature rotate the Lateral Side Bending Release Knob (No. 3) clockwise (from left side of table).
2. Turn the Lateral Side Bending Release Knob (No. 3) counterclockwise to lock headpiece in desired position (from left side of table).

CAUTION: MAKE SURE THE HEADPIECE IS LOCKED BEFORE ALLOWING A PATIENT ON OR OFF THE TABLE.

Manual Traction

1. To unlock the manual traction feature simply pull and twist the Traction Release Knob (No. 4) 1/4 of a turn clockwise or counterclockwise.
2. When unlocked the headpiece will glide forward and backward.
3. To lock the manual traction twist the Traction Release Knob (No. 4) 1/4 turn counterclockwise or clockwise.

Manual Flexion Distraction

1. To unlock the manual flexion distraction locate the Flexion / Tilt Knob (No. 5) pull forward and twist 1/4 turn counterclockwise.
2. Gently apply pressure down using the Flexion Assist Handle (No. 8).
3. To lock the manual flexion distraction twist the Flexion / Tilt Knob (No. 5) 1/4 turn clockwise and release to engage lock.

Tilting Feature

1. To unlock the Tilting feature locate the Flexion / Tilt Knob (No. 5) while supporting the head cushion pull forward and twist counterclockwise.
2. Once the desired angle is obtained, lock the headpiece simply by twisting the Flexion / Tilt Knob (No. 5) clockwise and release.

Rotation Feature

1. To unlock the Rotation feature locate the Rotation Release Knob (No. 6) Pull toward the head of the table and twist 1/4 turn clockwise.
2. Gently move the headpiece with the Flexion Assist Handle (No. 8)
3. To lock the Rotation feature locate the Rotation Release Knob (No. 6) twist 1/4 turn counter clockwise and release.

Face Opening Adjustment

1. The Head Cushion's Face Opening can be opened or closed to adjust for the comfort with the Face Opening Lever (No. 7). By pushing slightly down on the Face Opening Lever, slide side to side adjusting the face opening. The Face Opening Lever must be released in one of the eight positions to lock cushions in place.

Flexion Assist Handle

1. The Flexion Assist Handle (No. 8) has many functions including aiding with manual Cervical Flexion Distraction, rotation, lateral side bending, and tilting the headpiece.
2. To adjust the Flexion Assist Handle to desired comfort twist the Flexion Assist Handle locking Knobs on both sides of table. This will unlock the handle for adjustment. Twist in oppositedirection to lock.

Chest Cushion

The chest cushion is designed to accommodate patients with large or small abdomens and has the versatility of being a stationary or floating cushion.

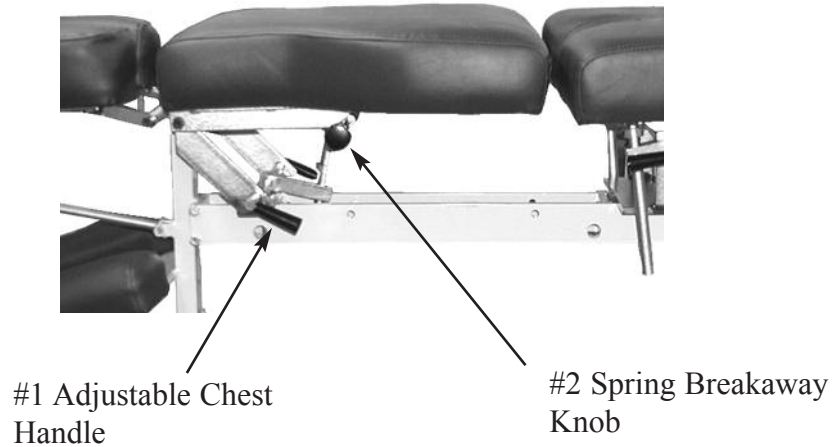

Standard - Adjustable Tilting Chest

Height Adjustment of Chest Cushion

1. Lift the rear corners of the cushion.
2. Release the cushion when the desired angle is reached and the cushion will automatically lock into place.

Tilting Chest Cushion Down

1. Support the cushion at the rear corners.
2. Lift on the Adjustable Chest Handle (No. 1) to release the cushion.
3. Slide the cushion to desired angle.
4. Release the Adjustable Chest Handle (No. 1) first and then the cushion to lock into desired height.

Optional Spring Breakaway Chest

To Engage Spring Breakaway Chest Cushion

1. Pull on Spring Breakaway Knob (No. 2) (facing the right side of the table) to unlock.
2. The resulting floating effect will allow the cushion to gently drop under pressure and spring back when released.

To Lock the Spring Breakaway Cushion

1. Gently pull up on chest cushion to full horizontal position, then Push on Spring Breakaway Knob (No. 2) (facing the right side of the table) to lock.

Pelvic Height Adjustment

#1 Adjustable Pelvic
Lock Handle

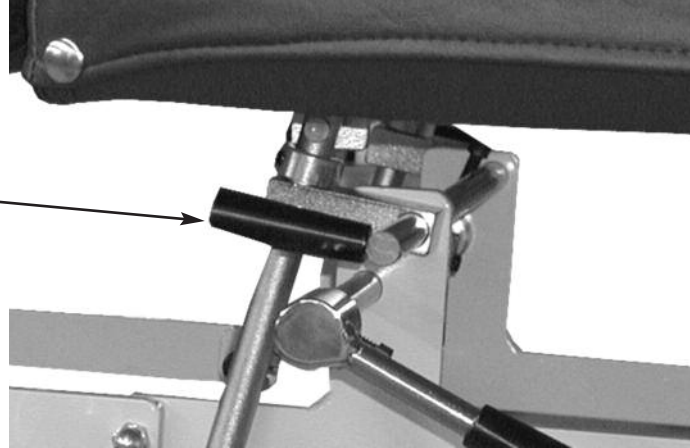

Pelvic Height Adjustment

Raising - Lift the cushion by its front corners to the desired height. The Cushion will lock in place once released.

Lowering - Support the cushion by slightly lifting up on a front corner. Next, lift the Adjustable Pelvic Lock Handle (No. 1) up and allow the cushion to slide down to desired height. Once adjusted to a desired height, release the lock handle and then the cushion to secure the height position.

Ankle Rest

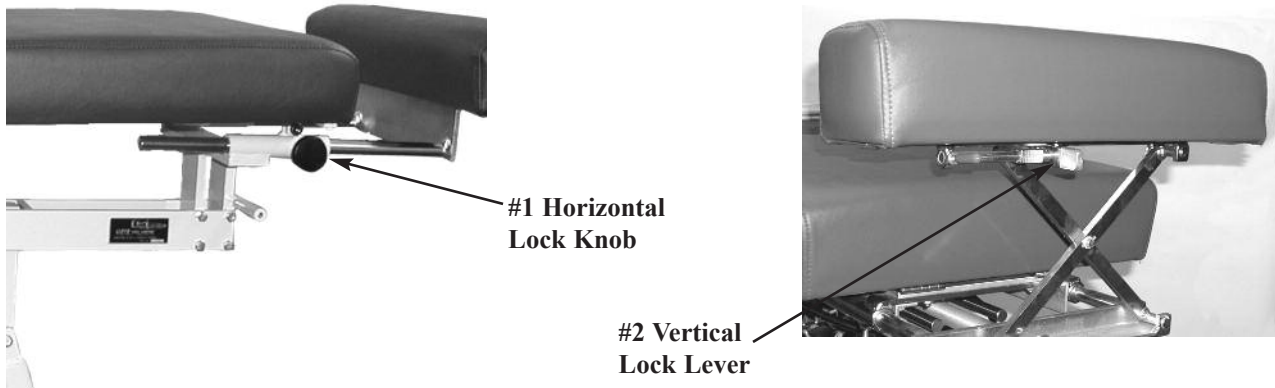

Ankle Rest Horizontal Adjustment

To Extend or Retract the Ankle Rest

1. Loosen the Horizontal Lock Knob (No. 1) and slide the cushion to the desired length.
2. Once the cushion is adjusted, tighten the lock knob.

Optional Vertical Ankle Rest

To Raise the Ankle Rest

1. Simply lift on the sides of the Ankle Rest Cushion.
2. Once the desired height is obtained the cushion will automatically lock into position when released.

To Lower the Ankle Rest

1. From the back end of the table, support the center of the Ankle Rest Cushion with the right hand.
2. With left hand, slide the Vertical Lock Lever (No. 2) towards the left side to release lock.
3. Lower the cushion to desired height, and release the Vertical Lock Lever to lock into place.

Master Power Switch

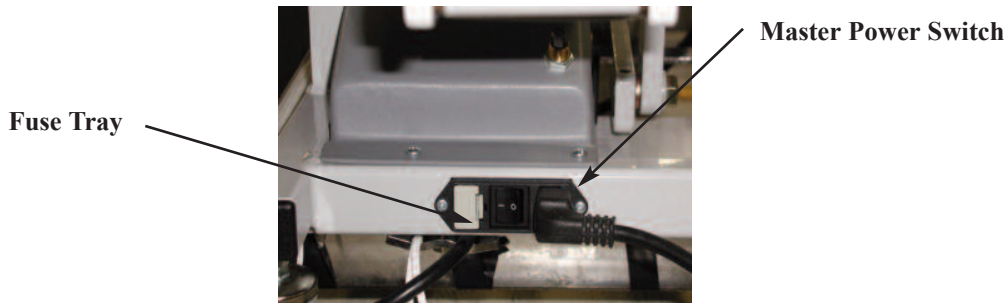

The Master Power Switch is located on the front left side of the base frame. The switch is operated by pushing on the left or right side, marked with a zero or dash. Once the power is on, select a Height Button to activate power to the table (Height Select Panel).

A. ON is indicated with a dash (-)

B. OFF is indicated with a Zero (0)



WARNING: WHEN THE TABLE IS NOT IN USE OR DOCTOR IS AWAY FROM THE TABLE, THE POWER SWITCH SHOULD BE TURNED OFF.

Power Switch Fuses



WARNING: UNPLUG THE POWER CORD FROM THE ELECTRICAL WALL OUTLET BEFORE REMOVING THE FUSE HOLDER TO AVOID INJURY.

A fuse holder tray is located next to the power switch and can be removed by pushing along the right side. Replace fuses with the same size rating.

Foot Pedal Control

Directional Pedal

The directional pedals have the dual function of horizontally raising and lowering the table in elevation. The directional pedals can be operated in manual and auto mode as described on page 13 (auto / manual).



Non - Corded Side - Lowers the table



Corded Side - Raises table



Optional - Electronic Height Adjustment (EHA)

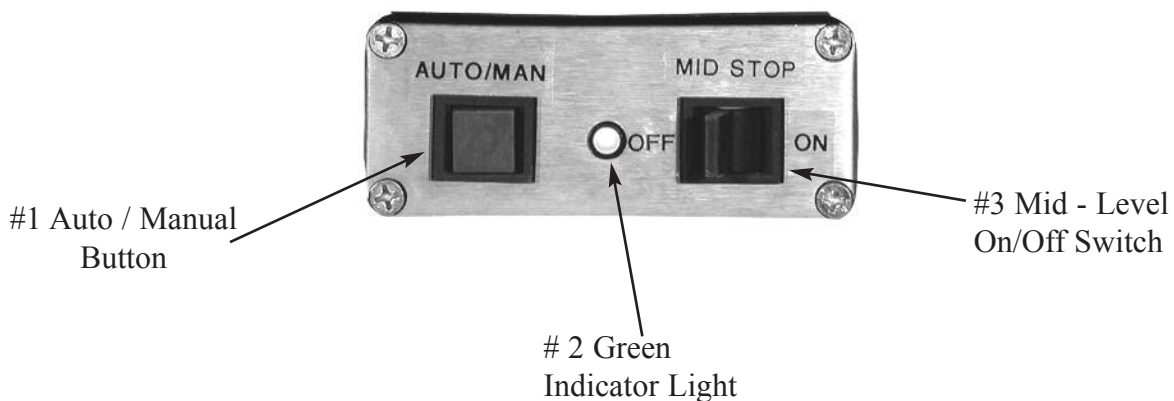

To Activate Electronic Height Adjustment:

1. Push the Auto / Manual Button(No. 1) Button to activate EHA. Once the Auto / Manual Button (No. 1) has been pressed note that the Green Indicator Light (No. 2) is now illuminated.
2. Toggle the Mid - Level On/Off Switch(No. 3). Toggle the switch toward the foot end of the table to activate the Mid-Level Stop. (If the Mid-Level Switch is “on” the table will stop at the programmed middle setting)

Toggle the switch towards the head end of the table to turn off the Mid-Level Stop.

(If the Mid-Level Switch is “off” the table will elevate or lower without stopping at the programmed middle setting)

3. Depress foot pedal once until the programmed height is achieved.

To Turn “Off” Electronic Height Adjustment

1. Push the Auto / Manual Button(No. 1) Button to activate EHA. Once the Auto / Manual Button (No. 1) has been pressed note that the Green Indicator Light (No. 2) is now off.
2. When the EHA is off the table is in manual mode, press the foot pedal until desired height is obtained and release pedal.

Electronic Height Adjustment (EHA)



#1 Upper Level
Adjustment

#2 Mid-Level
Adjustment

#3 Lower Level
Adjustment

To Set Programmed Heights for EHA:

To Set Upper Level:

1. Loosen Nut on the Upper Level Adjustment (No. 1) and slide towards the head end of table to increase height. **CAUTION: BE CAREFUL NOT TO SET TO FAR FORWARD AS THIS CAN CAUSE MOTOR TO KEEP RUNNING.**
Slide towards the foot end of the table to decrease height. Once height is obtained simply tighten nut to set level.

To Set Mid-Level:

1. Loosen Nut on the Mid-Level Adjustment (No. 2) and slide towards the head end of table to increase height. Slide towards the foot end of the table to decrease height. Once height is obtained simply tighten nut to set level.

To Set Lower-Level:

1. Loosen Nut on the Lower-Level Adjustment (No. 3) and slide towards the head end of table to increase height. Slide towards the foot end of the table to decrease height. Once height is obtained simply tighten nut to set level.

Chest Cushion - Manual Drops

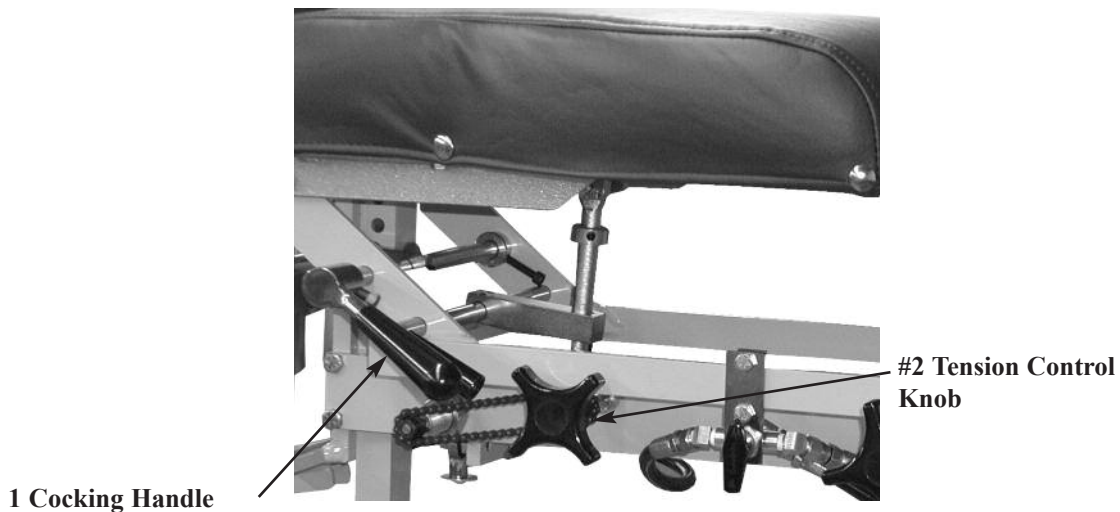

Chest & Lumbar Drop - Manual

Cocking the Drop Chest or Lumbar Cushion

1. Pull up on the Cocking Handle (No. 1) to cock the desired drop cushion.
2. Adjust the tension on drop by turning the Tension Control Knob (No. 2)

Right side: Clockwise - Decreases Tension

Counterclockwise - Increase Tension

Left Side: Clockwise - Increase Tension

Counterclockwise - Decrease Tension



CAUTION: THE DROP CUSHION TENSION SHOULD BE CHECKED AND TESTED BEFORE ADJUSTING PATIENT. KEEP FINGERS AWAY FROM BOTTOM OF CUSHION TO AVOID PINCHING

Lumbar / Pelvic Drop

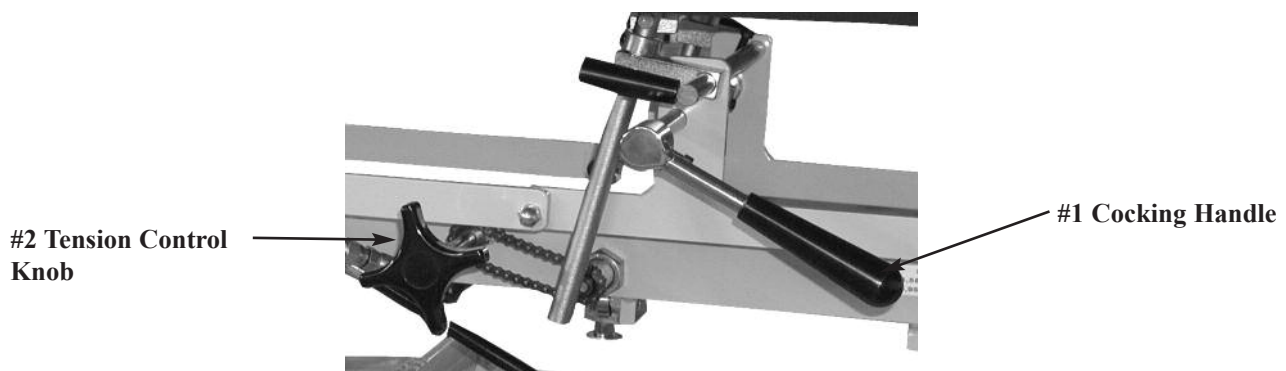

Lumbar / Pelvic Drop - Manual

Cocking the Drop Lumbar / Pelvic Cushion

1. Pull up on the Cocking Handle (No. 1) to cock the cushion.
2. Adjust the tension by turning the Tension Control Knob (No. 2)

Right side: Clockwise - Decreases Tension

Counterclockwise - Increase Tension

Left Side: Clockwise - Increase Tension

Counterclockwise - Decrease Tension



CAUTION: THE DROP CUSHION TENSION SHOULD BE CHECKED AND TESTED BEFORE ADJUSTING PATIENT. KEEP FINGERS AWAY FROM BOTTOM OF CUSHION TO AVOID

Automatic Cocking Drops

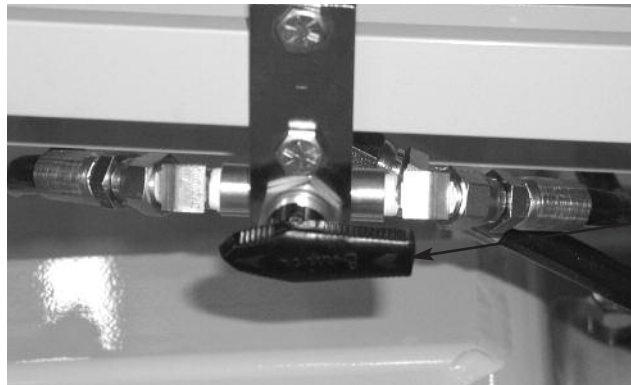

#1 Selector Knob

To Cock the Dorsal (Chest Cushion) Drop:

1. Rotate the Selector Knob (No. 1) towards the head of table to select the Dorsal (Chest Cushion) drop.
2. Step on the white strip to activate the auto cocking drop.



CAUTION: THE DROP CUSHION TENSION SHOULD BE CHECKED AND TESTED BEFORE ADJUSTING PATIENT. KEEP FINGERS AWAY FROM BOTTOM OF CUSHION TO AVOID PINCHING.

3. Adjust the tension on the drop by turning the Tension Control Knob (Refer to Page 10 for Instructions).

To Cock the Lumbar / Pelvic Cushion Drop:

1. Rotate the Selector Knob (No. 1) towards the foot end of table to select the Lumbar / Pelvic drop.
2. Step on the white strip to activate the auto cocking drop.



CAUTION: THE DROP CUSHION TENSION SHOULD BE CHECKED AND TESTED BEFORE ADJUSTING PATIENT. KEEP FINGERS AWAY FROM BOTTOM OF CUSHION TO AVOID PINCHING.

3. Adjust the tension on the drop by turning the Tension Control Knob (Refer to Page 10 for Instructions)

To Cock All Drops - Dorsal, Lumbar / Pelvic Drops

1. Rotate the Selector Knob (No. 1) towards the Mid Section of table to select the Dorsal, Lumbar / Pelvic drops.
2. Step on the white strip to activate the auto cocking drops.



402 STATIONARY FRAME ASSEMBLY

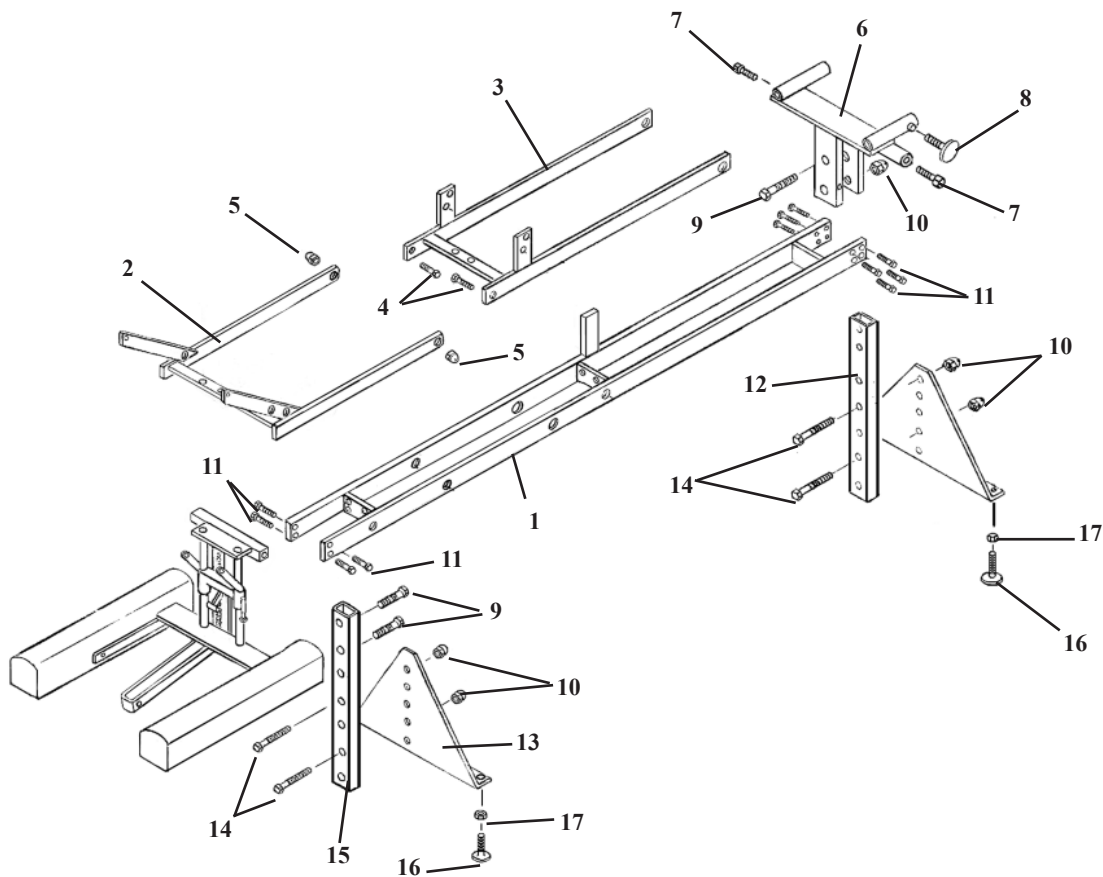

ITEM	PART NO.	DESCRIPTION	QTY.
1	56232	402 FRAME ASSEMBLY	1
2	56226	CHEST FRAME ASSEMBLY	1
3	56218	UNION FRAME ASSEMBLY	1
4	20204	BOLT, SOCKET HEAD, 5/16 - 18 NC SHOU 3/8 X 3/4	2
5	21114	NUT, CAP, 5/16 - 18 NC	2
6	56231	ANKLE BRACKET ASSEMBLY	1
7	20199	BOLT, SOCKET HEAD, 5/16 - 18 NC SHOU 3/8 X 1/2	2
8	24181	LOCK KNOB	1
9	20542	BOLT, HEX HEAD, 1/2 - 20 NF X 2 1/4 - CHROMED	2
10	21310	NUT, CAP, 1/2 - 20NF	6
11	20215	BOLT, HEX HEAD, 5/16 - 18 NC X 3/4	12
12	54219	LEG, REAR POST	1
13A	30013	TRIANGULAR LEG PLATE (21" - 26" TABLE)	2
13B	30012	TRIANGULAR LEG PLATE (20" TABLE)	2
13C	30591	TRIANGULAR LEG PLATE (18" TABLE)	2
14	20520	BOLT, HEX HEAD, 1/2 - 20 NF X 1 3/4	4
15	54205	LEG, FRONT POST	1
16	20373	BOLT, ELEVATOR, 3/8 - 16 NC X 1 1/2 (PLASTIC)	4
17	21211	NUT, JAM, 3/8 - 16 NC	4

702 ELEVATION BASE FRAME ASS'Y

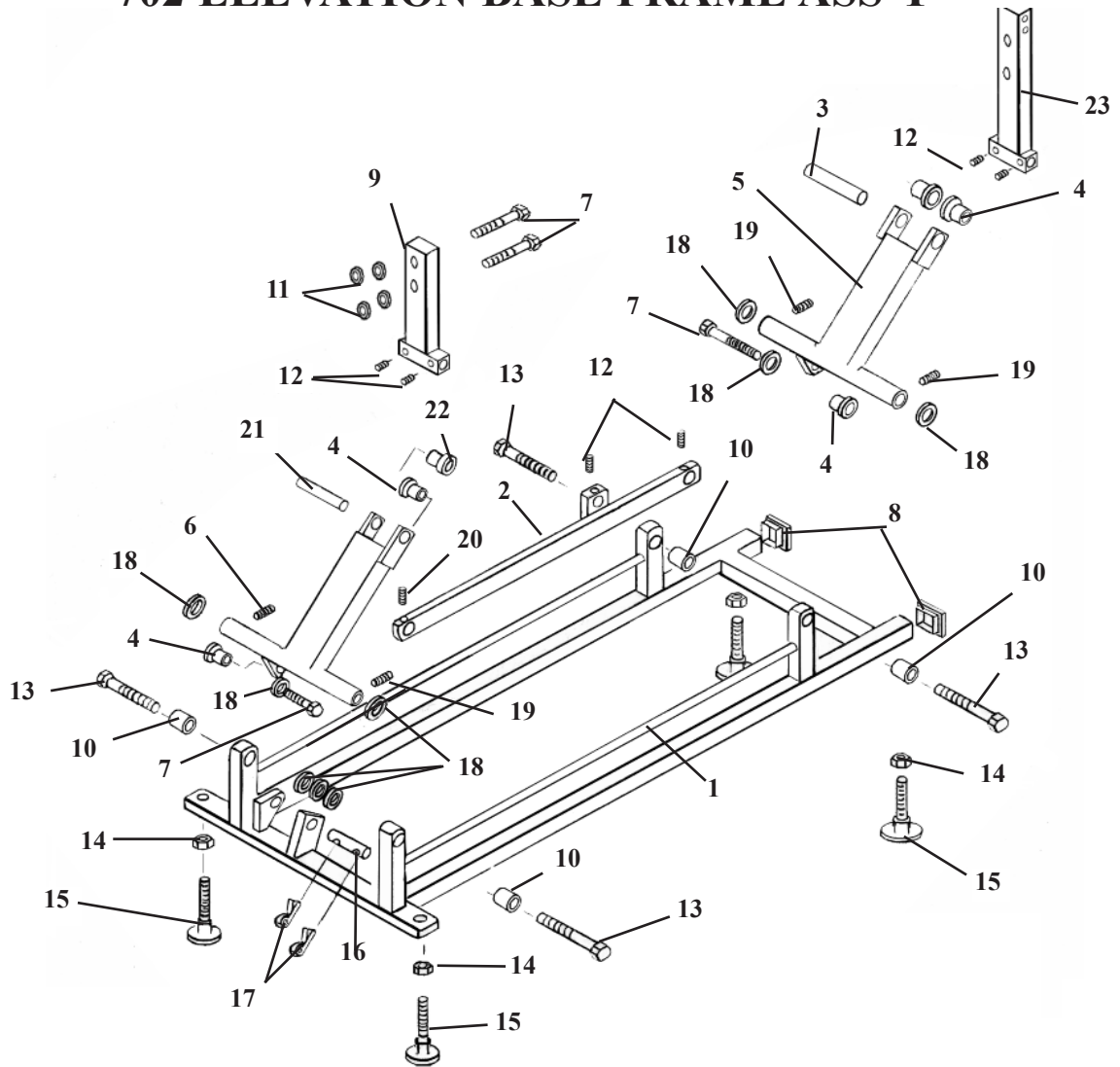

ITEM	PART NO.	DESCRIPTION	QTY.
1	54270	BASE FRAME ASS'Y	1
2	54339	TIE BAR	1
3	54145	FRONT CONNECTING PIN ½ RD. X 4 1/8	1
4	22888	CAP BUSHING	5
5	54155	DRIVER ARM ASS'Y (FRONT)	1
6	54303	DRIVER ARM ASS'Y (BACK)	1
7	20510	HEX. HD. BOLT, ½-20 UNF X 1 ¼	4
8	24414	CAP	2
9	56241	ROCKER ARM ASS'Y	1
10	22886	BRASS BUSHING, ½ ID X 5/8 OD X 1.00	4
11	21910	FLAT WASHER, ½ ID X 1 OD	4
12	22260	SET SCREW, 5/16-24 UNC X 1/4	4
13	56255	HEX. HD. BOLT, ½-20 UNF X 2 1/4	4
14	21210	HEX. NUT, 3/8-16 UNC	4
15	20373	ELEVATOR BOLT, 3/8-16 UNC 1 ½	4
16	22679	CYLINDER PIN, ½ RD. X 3 5/8	1
17	22640	COTTER PIN 3/32 X 1.00	2
18	20912	WASHER,FLAT, PLASTIC, ½ ID X 1 ½ OD	8
19	22110	SET SCREW, ¼-20 UNC X ¼	4
20	22250	SET SCREW, 5/16-24 UNF X ½	1
21	58151	REAR CONNECTION PIN, ½ RD. X 3 ½	1
22	22889	CAP BUSHING	1
23	54037	ROCKER ARM ASS'Y	1

TILT HEAD CUSHION ASS'Y

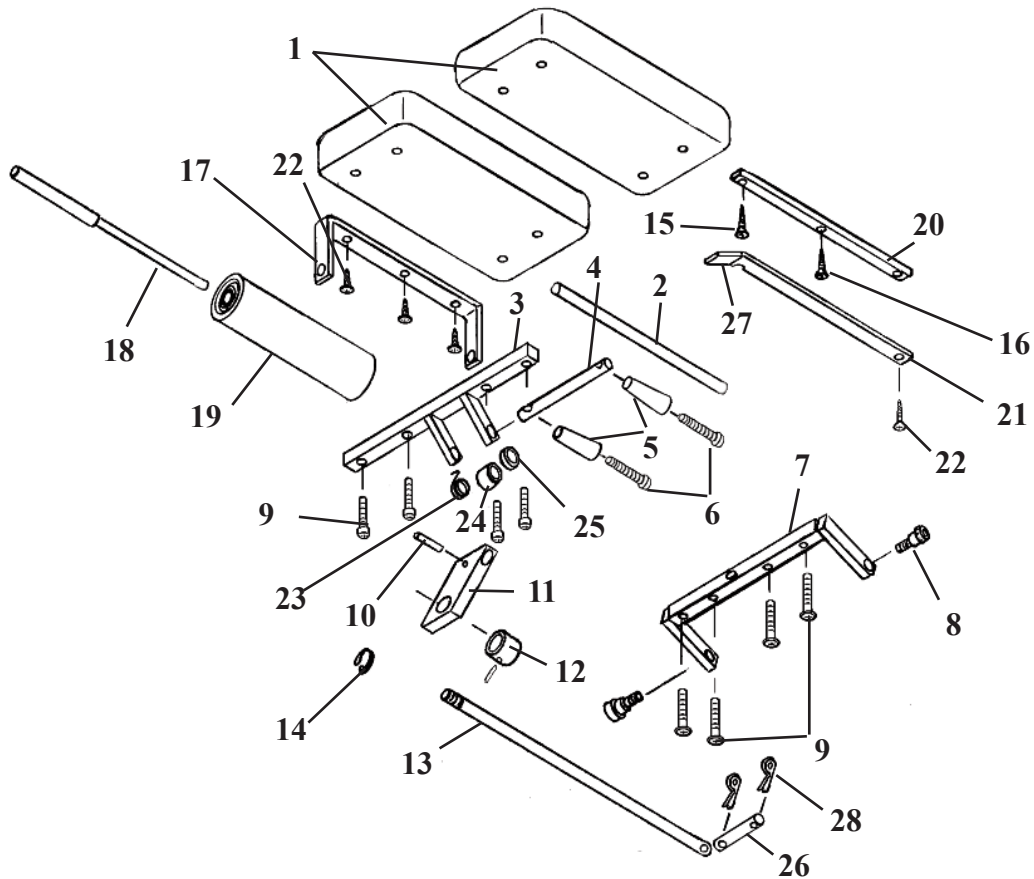

ITEM	PART NO.	DESCRIPTION	QTY.
1	40654	HEAD CUSHION	2
2	57936	CENTER ROD	1
3	56381	FRONT BRACE	1
4	56152	ADJUSTMENT ROD	1
5	24020	HANDLE	1
6	22050	RD. HEAD SCREW, 1/4-20 UNC X 2 1/2	2
7	56396	BACK BRACE	1
8	20003	SOCKET HD. BOLT, 1/4-20 UNC X 1/2	2
9	20023	Bol, Hex HD, 1/4-20 X 1 1/4	8
10	22675	ROLL PIN	1
11	54107	ADJUSTING BLOCK	1
12	22913	COLLAR	1
13	54142	EYE ROD, TILT, 1/2 X 15 13/16	1
14	22508	FLAT HD. SCREW, #10 X 7/8	1
15	22455	RD. HD. SCREW, #8 X 3/4	4
16	24285	E-CLIP	1
17	56305	PAPER HANGER	1
18	57956	HANGER ROD ASS'Y	1
19	29999	PAPER ROLL	1
20	57934	INSIDE BAR	1
21	57933	OUTSIDE CUTTING BAR	1
22	22468	SHEET METAL SCREW, #10 X 7/8	1
23	30870	TORSION SPRING	1
24	22912	COLLAR, 3/8 ID	1
25	21912	PLASTIC WASHER, 1/2 ID X 1 1/4 OD	1
26	24235	PIN, 5/16 X2	1
27	24235	PLASTIC GUARD	1
28	22640	COTTER PIN	2

DELUXE HEAD CUSHION ASS'Y

NOTE: ITEM #20 IS USED WITH THE STRAIGHT DROP HEAD CUSHION

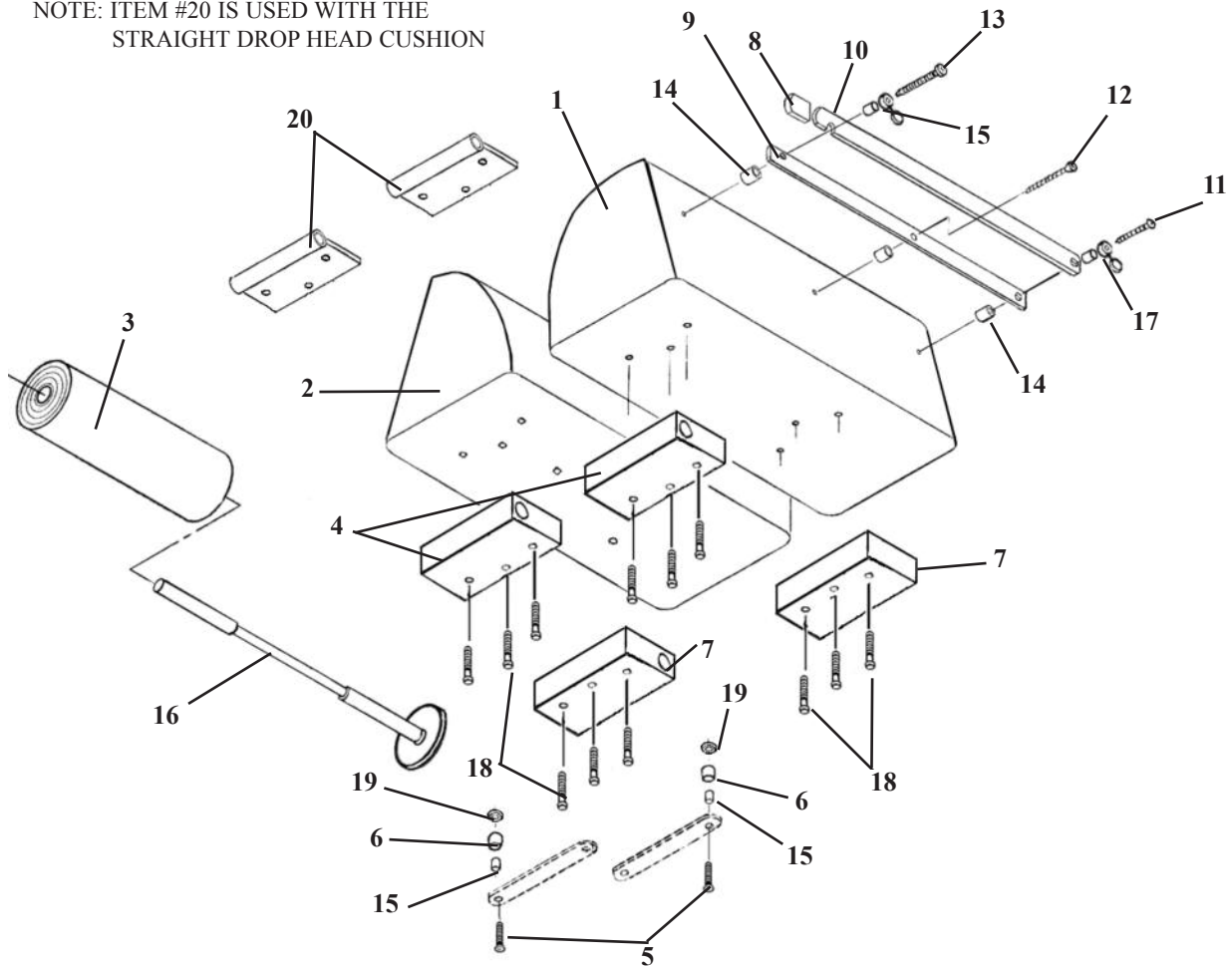

ITEM	PART NO.	DESCRIPTION	QTY
1	40110	CUSHION, HEAD - LEFT HAND	1
2	40130	CUSHION, HEAD - RIGHT HAND	1
3	29999	HEADREST PAPER	1
4	30400	SLIDE BLOCK, FRONT	2
5	22009	OVAL HD. MACHINE SCREW, #10-24 NC X 1 1/2	2
6	57174	SPACER, 3/16 ID X 1/2 OD X 5/8	2
7	30401	SLIDE BLOCK, REAR	2
8	24235	GUARD, CUTTING BAR	2
9	50750	INSIDE CUTTING BAR	1
10	50770	OUTSIDE CUTTING BAR	1
11	22550	RD. HD. WOOD SCREW #14 X 2.00	1
12	22510	FLAT HD. WOOD SCREW, #9 X 1 1/2	1
13	22522	RD. HD. WOOD SCREW, #9 X 2.00	1
14	50720	SPACER, PAPER CUTTER, 3/8 ID X 1/2 OD	3
15	22860	BUSHING, 3/16 ID x 1/4 OD	3
16	50778	PAPER HANGER ASS'Y, w/ Washer	1
17	21610	FLAT WASHER, 3/16 ID X 1/2 OD	1
18	22003	OVAL HD. MACHINE SCREW, #10 - 24 NC X 3/4	12
19	21510	FLAT WASHER, 3/16 ID X 1/2 OD	2
20	57155	GUIDE TUBE ASS'Y, FRONT	2

DELUXE HEAD FRAME ASS'Y

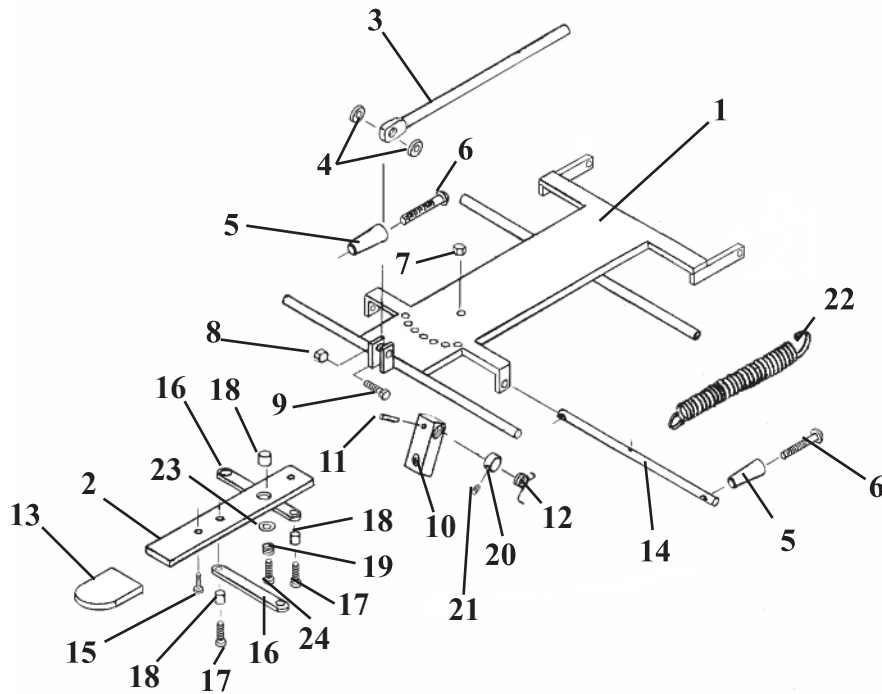

ITEM	PART NO.	DESCRIPTION	QTY.
1	56051	FASTNER PLATE ASS'Y	1
2	57221	ADJUSTMENT ARM	1
3	55929	CENTER BAR	1
4	21616	PLASTIC FLAT WASHER, ¼ ID X ¾ OD	2
5	24020	HANDLE	2
6	22050	RD. HD. MACHINE SCREW, ¼-20 UNC X 2 ½	2
7	21450	HEX. NUT, #10-24 UNC	1
8	21020	HEX. NUT, ¼-28 UNF	1
9	20115	HEX. HD. BOLT, ¼-28 UNF X 1.00	1
10	54107	ADJUSTMENT BLOCK	1
11	22670	ROLL PIN, 1/8RD. X ¾	1
12	30870	TROSION SPRING	1
13	24236	PLASTIC CAP	1
14	57205	ADJUSTMENT ROD, 7/16 RD. X 9 5/8	1
15	22300	RD. HD. MACHINE SCREW, #8-32 UNC X ¼	1
16	57175	LINKAGE BAR, 1/8 X ½ X 3 9/16	2
17	21995	PAN HD. MACHINE SCREW, #10-24 UNC X ½	3
18	22860	BUSHING, 3/16 ID X 1/4OD X .16	3
19	30722	COMPRESSION SPRING, .235 ID X .5/16 OD X ½	1
20	22912	COLLAR, 3/8 ID	1
21	22110	SET SCREW, ¼-20 UNC X ¼	1
22	30785	TENSION SPRING, ½ ID X 5/8 OD X 7 1/8 (HYLO ONLY)	1
23	21610	WACHER, .26 ID X ½ OD	1
24	22003	PAN HE. MACHINE SCREW, #10-24 UNC X ¾	1

I - FRAME ASSEMBLY DELUXE, FORWARD MOTION & FLEXION HEAD

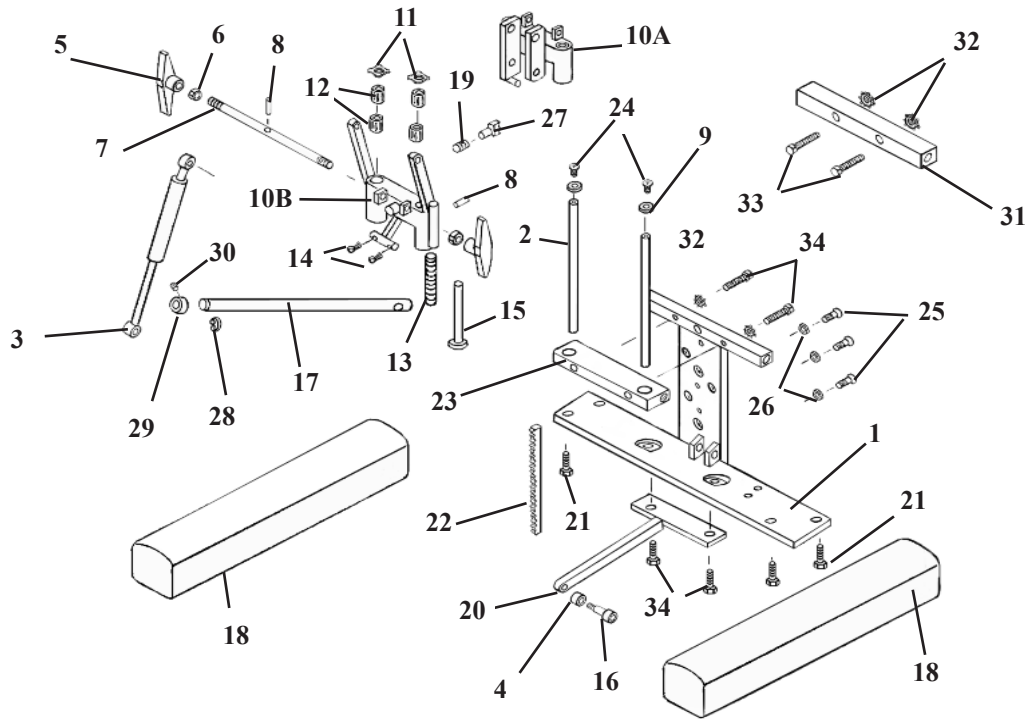

ITEM	PART NO.	DESCRIPTION	QTY.
1	54193	I - FRAME ASSEMBLY	1
2	50872	GUIDE ROD	2
3A	30296	CYLINDER, F/M 89 & FLEXION HEAD, 50 #	1
3B	30297	CYLINDER, DELUXE 89 HEAD, 40 #	1
4	56006	SPACER, 3/8 ID X 1/2 OD	1
5	24186	TENSION KNOB	2
6	21210	NUT, HEX, 3/8 - 16 NC	2
7	55949	ROD, ADJUSTMENT, 3/8 RD X 11	1
8	22675	ROLL PIN, 1/8 X 3/4	2
9	21620	WASHER, FLAT, 1/4 ID X 9/16 OD	2
10A	55750	SHUTTLE ASSEMBLY, FLEXION HEAD	1
10B	56045	SHUTTLE ASSEMBLY, F/M & DELUXE HEAD	1
11	24050	SPRING CLIPS	4
12	22891	BUSHING, 1/2 ID X 1 OD	4
13	30740	SPRING, COMPRESSION, 5/16 ID X 4 3/4	1
14	22640	COTTER PIN, 3/32 X 1	2
15	55959	PLUNGER ASSEMBLY	1
16	20003	BOLT, SOCKET HD, 1/4-20 X SHLD. 5/16 X 1/2	1
17	54108	ROD, TILT LOCK, 1/2 RD X 13 13/16	1
18	40839	ARM REST CUSHION	2
19	30750	SPRING, COMPRESSION	1
20	54243	EXTENSION TONGUE ASS'Y	1
21	20052	BOLT, HEX HEAD, 1/4 - 20 NC X 1 3/4	4
22	56019	GEAR RACK	1
23	56145	SPACER, PLATE, 3/8 X 1 1/4 X 4 9/16	1
24	22013	SCREW, MACHINE, BUTTON SOC HEAD, 1/4 - 20 NC X 1/2	2
25	21975	SCREW, MACHINE, PAN HEAD, #6 - 32 X 1/2	3
26	21510	WASHER, FLAT, 3/16 ID X 1/2 OD	3
27A	56064	LOCK PIN ASSEMBLY, F/M & DELUXE HEAD	1
27B	56007	LOCK PIN ASSEMBLY, FLEXION HEAD	1
28	24285	SNAP RING, 1/2"	1
29	22913	SET COLLAR, 1/2"	1
30	22110	SET SCREW, 1/4-20UNC x 1/4	1
31	56393	SPACER, 5/8 X 1 X 7 7/16	1
32	21630	WASHER, STAR, 1/4 ID	4
33	20055	BOLT, HEX HEAD, 1/4 - 20 NC X 2	2
34	20022	BOLT, HEX HEAD, 1/4-20 UNX X 1	4

ADJUSTABLE TILT CHEST ASSEMBLY

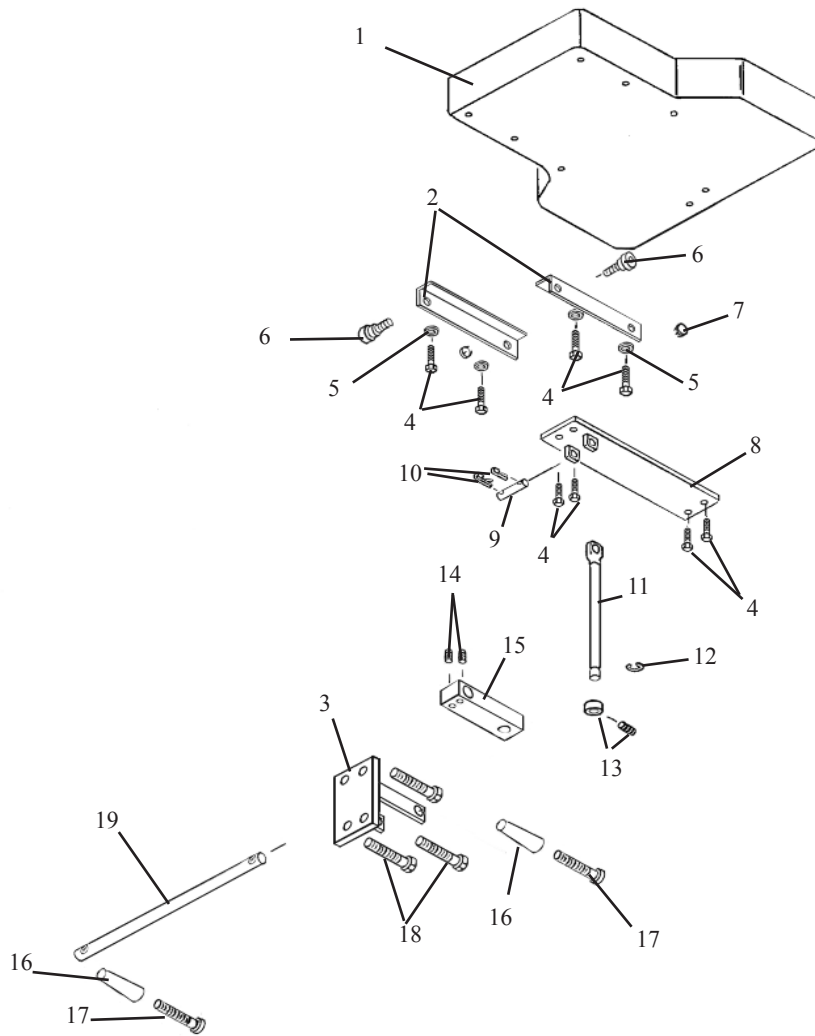

ITEM	PART NO.	DESCRIPTION	QTY.
1A	40210	CUSHION, CHEST – STANDARD	1
1B	40230	CUSHION, CHEST-WIDE	1
2	56416	ANGLE BRACE, 1/8 x 1 1/4 x 1 1/4 x 6 1/2	1
3	56620	SUPPORT BRACKET	1
4	20022	BOLT, HEX HD. 1/4-20 UNC X 1	6
5	21620	WASHER, FLAT, 1/4 ID X 9/16 OD	4
6	20199	SOCKET HD. SHOULDER BOLT, 5/16-18 UNC - SHD. 3/8 DIA.	2
7	55945	BUTTON,	2
8	55149	SUPPORT BRACKET ASS'Y	1
9	51920	PIN, EYEROD, 1/2 X 2 3/8	1
10	22640	COTTER PIN,	2
11	56409	EYE ROD ASS'Y	1
12	24286	SNAP RING, 9/16	1
13	22935	SET COLLAR, 9/16 ID	1
14	22110	SET SCREW, 1/4-20UNC X 1/4	2
15	54082	DROP BLOCK	1
16	24020	ADJUSTMENT HANDLE	2
17	22050	RD. HD. MACHINE SCREW, 1/4-20 UNC X 2 1/2	2
18	50356	HEX. HD. BOLT, 1/2-20 unc x 2	4
19	56235	ROD, ADJUSTMENT, 1/2 RD X 12 1/2	1

DELUXE CHEST CUSHION SPRING BREAKAWAY

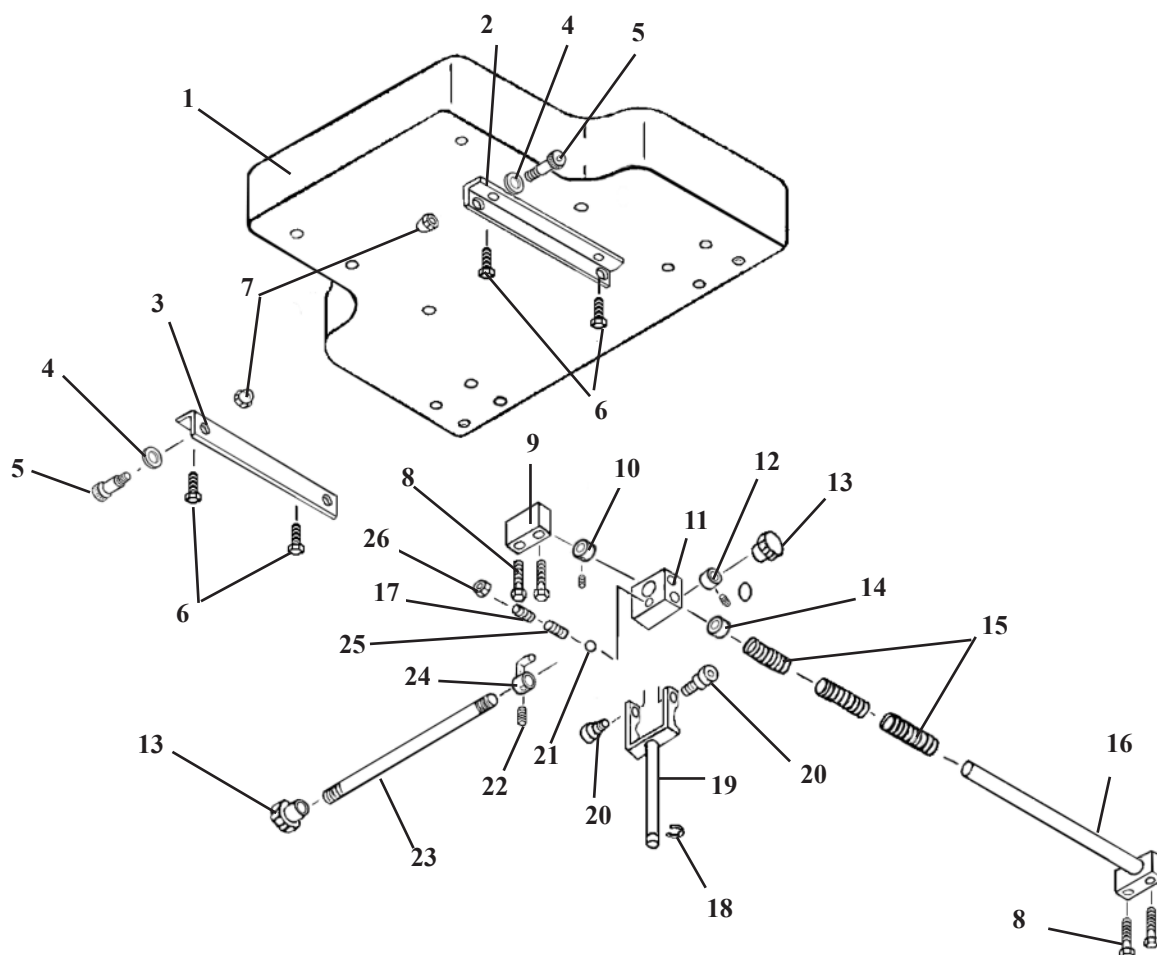

ITEM	PART NO.	DESCRIPTION	QTY.
1	40210	CHEST CUSHION -STANDARD	1
2	51010	CUSHION BRACE (LH)	1
3	51030	CUSHION BRACE (RH)	1
4	21800	WASHER, PLASTIC, 3/8 ID X 5/8 OD	2
5	20199	BOLT, SOCKET HD, 5/16-18UNC, SHOU 3/8 X 1/2	2
6	20022	BOLT, HEX HEAD, 1/4 - 20UNC X 1	6
7	21114	CAP, NUT, 5/16-18 UNC	2
8	20052	BOLT, HEX HD, 1/4-20UNC X 1 3/4	4
9	51110	SUPPORT BLOCK	1
10	22940	COLLAR, 5/8 ID	1
11	51090	BLOCK YOKE	1
12	22922	COLLAR, 5/16 ID X 5/8 OD	1
13	24150	LOCK KNOB	2
14	22854	BUSHING, 5/8 ID X 23/32 OD	1
15	30793	COMPRESSION SPRING, 11/16 ID X 15/16 OD X 3 1/8	3
16	51068	SUPPORT ROD ASS'Y	1
17	22120	SET SCREW, 1/4 - 20UNC X 1/2	1
18	24286	SNAP RING 9/16	1
19	56289	FORK ASS'Y	1
20	20197	BOLT, SOCKET HD., 5/16-18UNC, SHOU 3/8 X 3/8	2
21	22702	STEEL BALL, 3/16 DIA	1
22	22090	SET SCREW, #10-32 UNF x 3/16	1
23	51057	ADJUSTMENT ROD, 3/8 RD X 7 1/4	1
24	50570	LOCK PIN	1
25	30715	SPRING, COMPRESSION, 3/16 ID X 5/32 OD	1
26	21012	JAM NUT, 1/4 - 20UNC	1

ADJUSTABLE TILT PELVIC ASSEMBLY

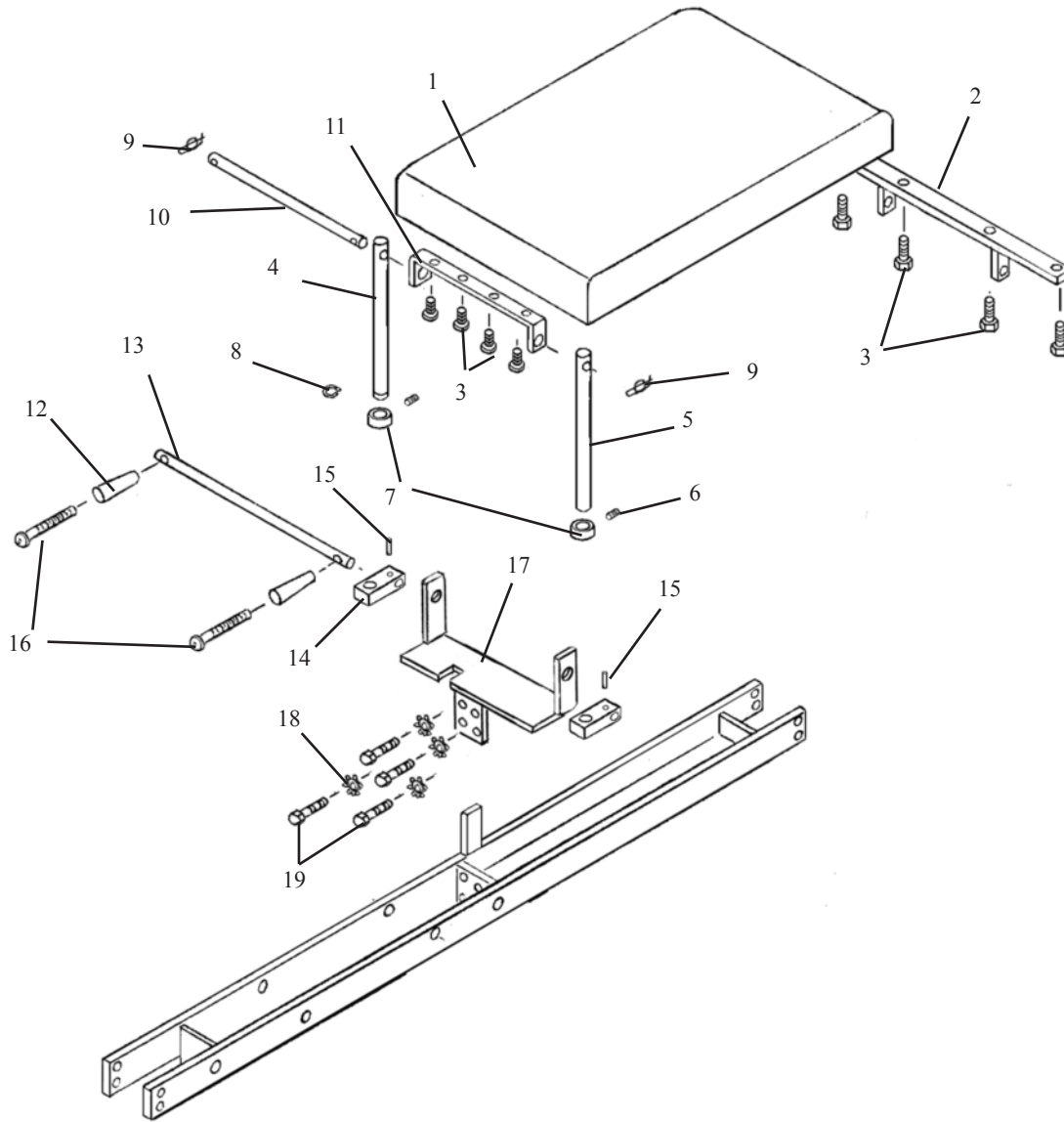

ITEM	PART NO.	DESCRIPTION	QTY.
1	40284	PELVIC CUSHION	1
2	54213	REAR HINGE BRACKET	1
3	20022	BOLT, HEX. HEAD, 1/4-20UNC X 1 1/4	8
4	57735	EYE-ROD, 9/16 X 7 13/16 (groove)	1
5	57738	EYE-ROD, 9/16 X 7 13/16	1
6	22110	SET SCREW, 1/4-20UN X 1/4	2
7	22935	SET COLLAR, 9/16 ID X 1.00 OD	2
8	24286	SNAP RING, 9/16	1
9	55090	SET SCREW, #10-32UNC X 1/4	2
10	57745	STABILIZER ROD 3/8 RD X 10 7/8	1
11	57720	FRONT BRACKET ASS'Y	1
12	24020	HANDLE ADJUSTMENT	2
13	57739	ADJUSTMENT ROD 1/2 RD. X 17	1
14	57737	ADJUSTMENT BLOCK 5/8 X 1 X 2 1/2	2
15	22660	ROLL PIN 1/8 X 5/8	2
16	22050	RD. HD. MACHINE SCREW, 1/4-20UNC X 2 1/2	2
17	56317	HANGER BRACKET ASS'Y	1
18	21850	STAR WASHER 3/8 ID	4
19	20332	HEX. HD. BOTL, 3/8 - 16 UNC X 1.00	6

ANKLE REST ASSEMBLY

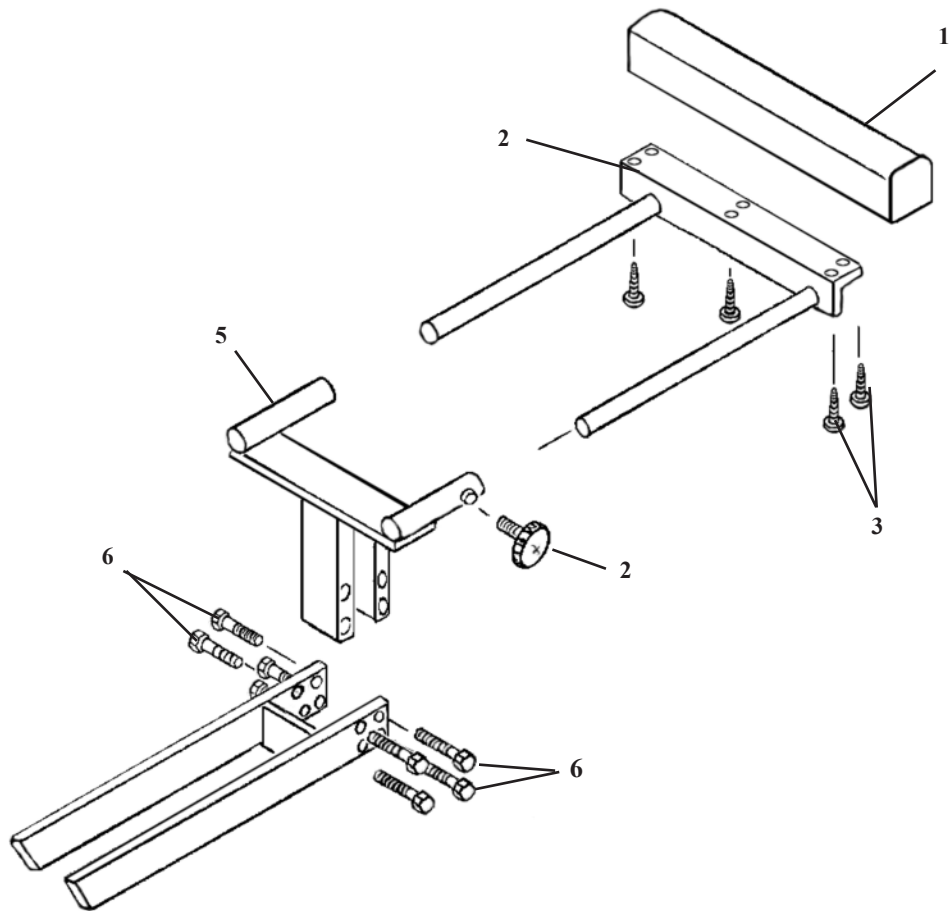

ITEM	PART NO.	DESCRIPTION	QTY.
1	40410	ANKLE REST CUSHION	1
2	54206	SLIDE BRACKET ASS'Y	1
3	22468	PAN HD. WOOD SCREW, #10 X 7/8	6
4	24181	LOCK KNOB	1
5	56231	ANKLE BRACKET ASS'Y	1
6	20215	BOLT, HEX HD, 5/16-18 UNC X 3/4	8

ANKLE REST ASSEMBLY

ADJUSTABLE HEIGHT

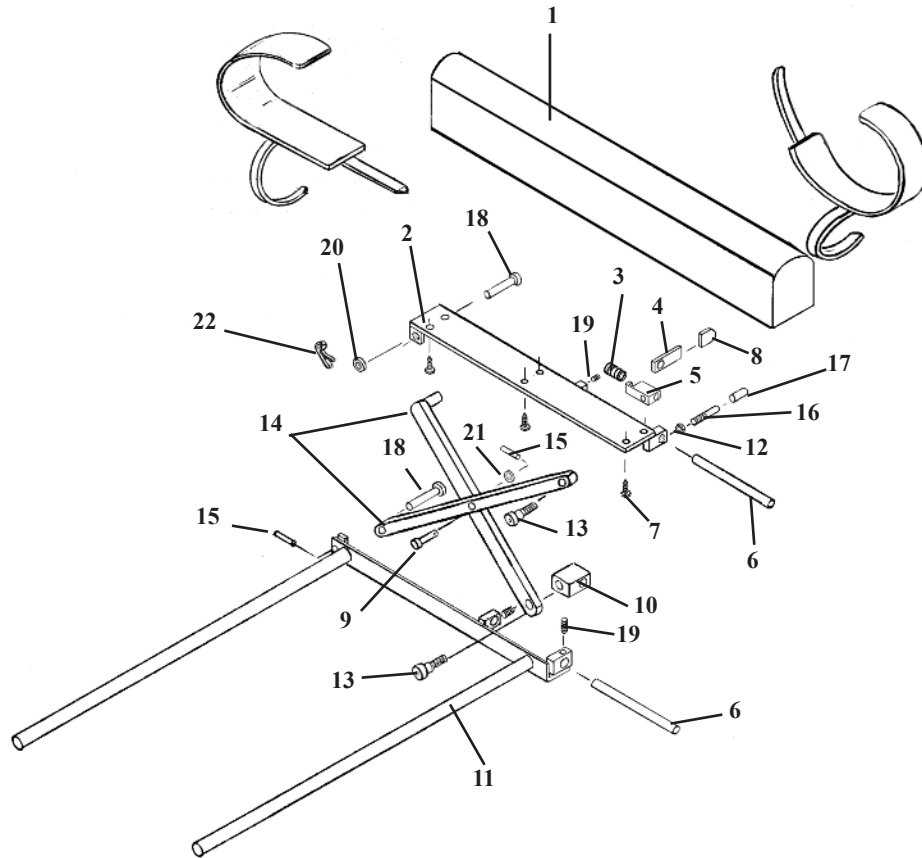

ITEM	PART NO.	DESCRIPTION	QTY.
1	40410	ANKLE REST CUSHION	1
2	56507	BASE PLATE	1
3	30774	COMPRESSION SPRING	1
4	56519	LOCK HANDLE	1
5	56525	GUIDE BLOCK	1
6	56518	GUIDE ROD	2
7	22468	SCREW, WOOD, RD HEAD, #10 X 7/8	6
8	24236	GUARD, TEE HANDLE	1
9	22610	PIN, CLEVIS, 5/16 X 7/8	1
10	56539	GUIDE BLOCK	1
11	56515	SLIDE FRAME ASS'Y	1
12	21010	NUT, HEX, 1/4 - 20 UNC	1
13	20197	BOLT, SOCKET, SHOULDER, 5/16-18 UNC X 3/4	2
14	56512	LINKAGE ARM ASSEMBLY	2
15	22660	ROLL PIN, 1/8 X 5/8	2
16	52190	EXTENSION ROD	1
17	24415	PLASTIC CAP	1
18	22615	PIN, CLEVIS, 5/16 X 2	2
19	22110	SET SCREW, 1/4 - 20 UNC X 1/4	3
20	21710	WASHER, FLAT, 5/16 ID	1
21	21760	WASHER, FLAT, PLASTIC, 0.315 ID X 1/2 OD	1
22	22640	COTTER PIN	1

HYDRAULICS ASSEMBLY

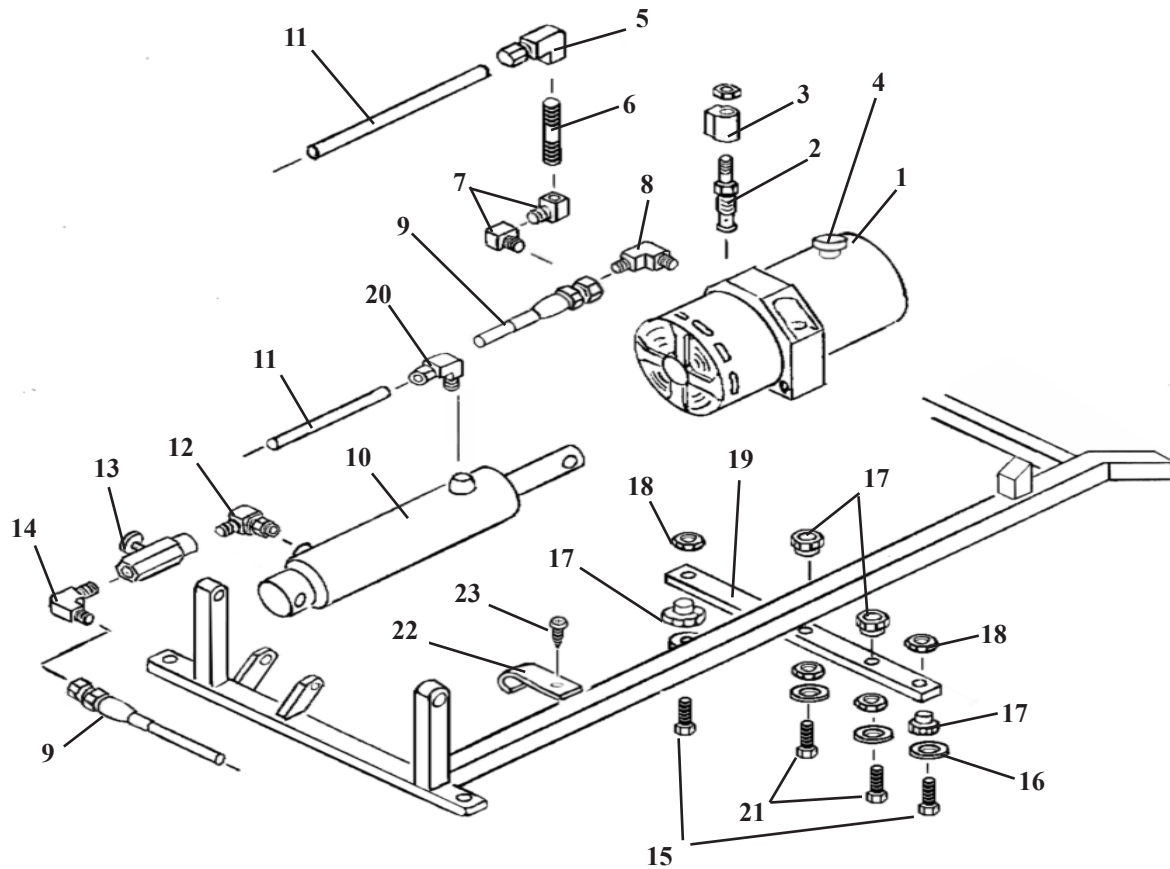

ITEM	PART NO.	DESCRIPTION	QTY.
1	30495	PUMP & MOTOR, (115v)	1
2	23568	POPPET VALVE	1
3A	35990	SOLENOID COIL, 110V	1
3B	36005	SOLENOID COIL, 24V	1
4	36970	VENT CAP	1
5	23133	FITTING 90 DEG-1/8NPT-1/4 COMPRESSION	1
6	23326	PIPE NIPPLE	1
7	23130	FITTING 90 DEG- 1/8MALE-FEMALE	2
8	23110	FITTING 90 DEG- 1/8 JIC - MALE	1
9	45250	HYDRAULIC HOSE, 3/16 X 15"	1
10	56958	CYLINDER, ELEVATION	1
11	23614	LEGRIS HOSE, 1/4 X 18"	1
12	23127	FITTING 90 DEG- 1/8 PIPE	1
13	23577	CONTROL VALVE	1
14	23090	FITTING 90 DEG- 1/8 JIC	1
15	20123	HEX HD BOLT, 1/4-28 UNF X 1 1/4	2
16	21640	FLAT WASHER, 9/32 ID X 1.00 OD	4
17	22895	RUBBER BUSHING (MALE)	4
18	24035	RUBBER BUSHING (FEMALE)	4
19	54168	MOTOR PLATE	1
20	23129	FITTING, 90 DEG- 1/8NPT - 1/4 COMPRESSION	1
21	20020	HEX HD. BOLT, 1/4-20UNX 1.00	2
22	52072	J-CLAMP	1
23	21995	MACHINE SCREW, PAN HEAD, #10-24UNC X 1/2	1

AUTO DROP HYDRAULIC ASSEMBLY

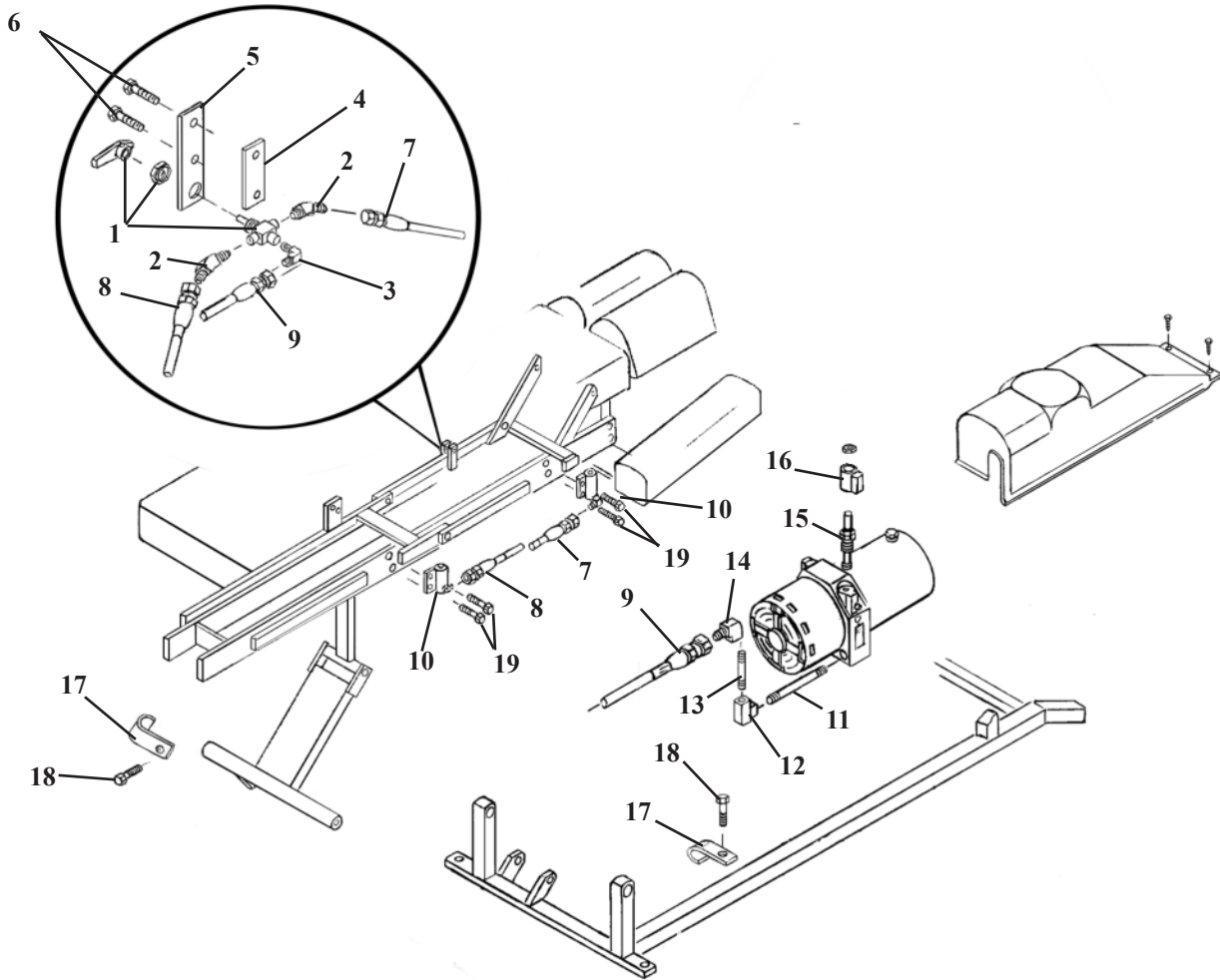

ITEM	PART NO.	DESCRIPTION	QTY.
1	23573	SELECTOR VALVE	1
2	23090	FITTING, 45 DEG, 1/8 MALE-JIC	2
3	23110	FITTING, 90 DEG, 1/8 MALE-JIC	1
4	56259	MOUNTING BRACKET	1
5	56260	BACKING PLATE	1
6	20020	BOLT, HEX HEAD, 1/4 - 20 NC X 1 1/4	2
7	45219	HOSE, HYDRAULIC, 3/16 X 11 1/2"	1
8	45230	HOSE, HYDRAULIC, 3/16 X 14"	1
9	45360	HOSE, HYDRAULIC, 3/16 X 49 1/2"	1
10	625020	COCKING CYLINDER, 3/4" ROUND-FRONT PORT	2
11	23336	NIPPLE, PIPE 1/8"x 5	1
12	23132	FITTING, 90 DEG, 1/8 FEMALE-JIC	1
13	23326	NIPPLE, PIPE 1/8" X 2 1/2	1
14	23112	FITTING, 90 DEG, 1/8 FEMALE-JIC	1
15	23518	VALVE, 4-WAY, 2 POSITION w/CROSS-OVER CENTER	1
16	36012	COIL, SOLENOID, 24V	1
17	52072	J-CLAMP,	2
18	21995	PAN HD. MACHINE SCREW, #10 - 24 NC X 1/2	1
19	20112	HEX. HD. BOLT, 1/4-28 UNF X 5/8	4

ELECTRICAL ASS'Y

402 ELEVATION

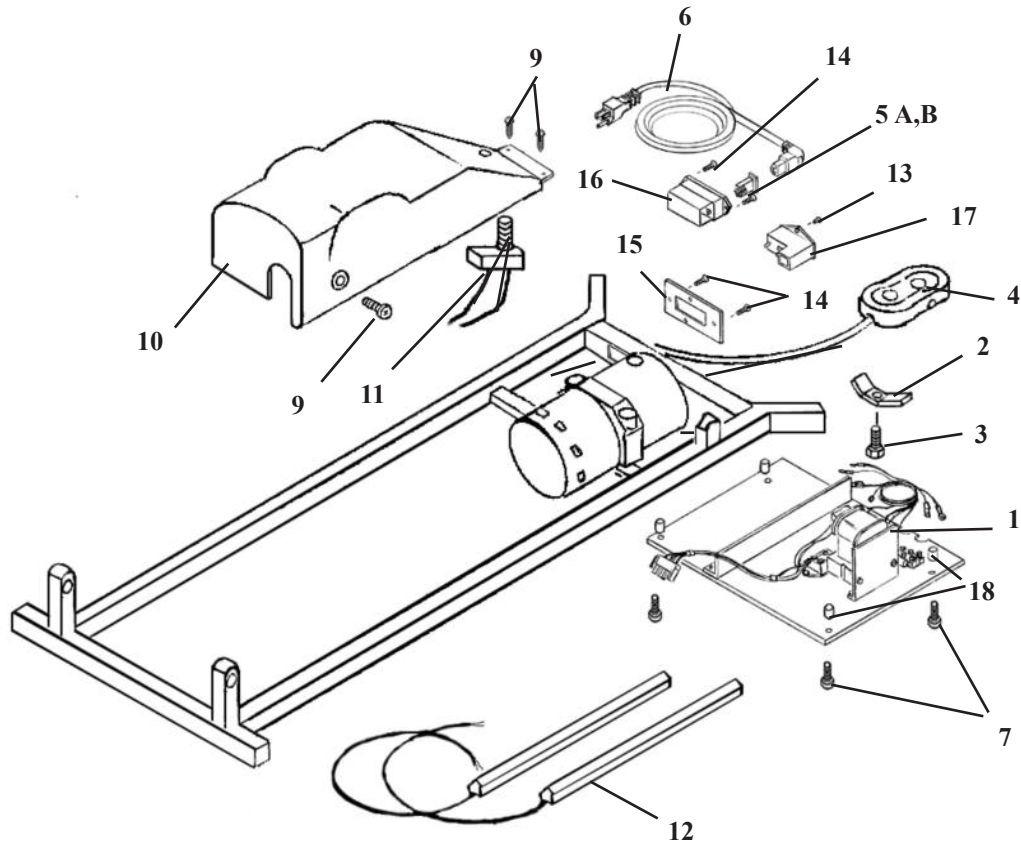

ITEM	PART N0.	DESCRIPTION	QTY.
1	44974	ELECTRICAL UNIT ASS'Y, (AUTO DROP)	1
2	52073	CLAMP	1
3	20022	HEX HD BOLT, ¼-20UNC X	1
4	30910	HEIGHT CONTROL PEDAL	1
5A	35377	FUSE HOLDER, 110V	1
5B	36378	FUSE HOLDER, 220V	1
6	45199	POWER CORD	1
7	22320	PAN HD MACHINE SCREW, #10-24 UNC X 1	4
8	699195	COVER	1
9	21995	PAN HD MACHINE SCREW, #10-24UNC X ½	3
10	21071	TEE NUT, #10-24UNC	1
11	38040	LIMIT SWITCH	1
12	44096	TAPEZ SWITCH ASS'Y - 12"	1
13	21972	FLAT HEAD SCREW, # 6-32 UNC X 1/4	2
14	21980	FLAT HEAD SCREW, # 6-32 UNC X 1/2	2
15	58618	ADAPTER PLATE, 1/8 X 2 X 3 9/16 (100 V ONLYe)	1
16	44217	POWER ENTRY / 110 & 220 V	1
17	37186	POWER ENTRY 100V	1
18	50720	SPACER 3/8 ID X 1/2 OD	4

ELECTRICAL ASSEMBLY

EHA & AUTO DROPS

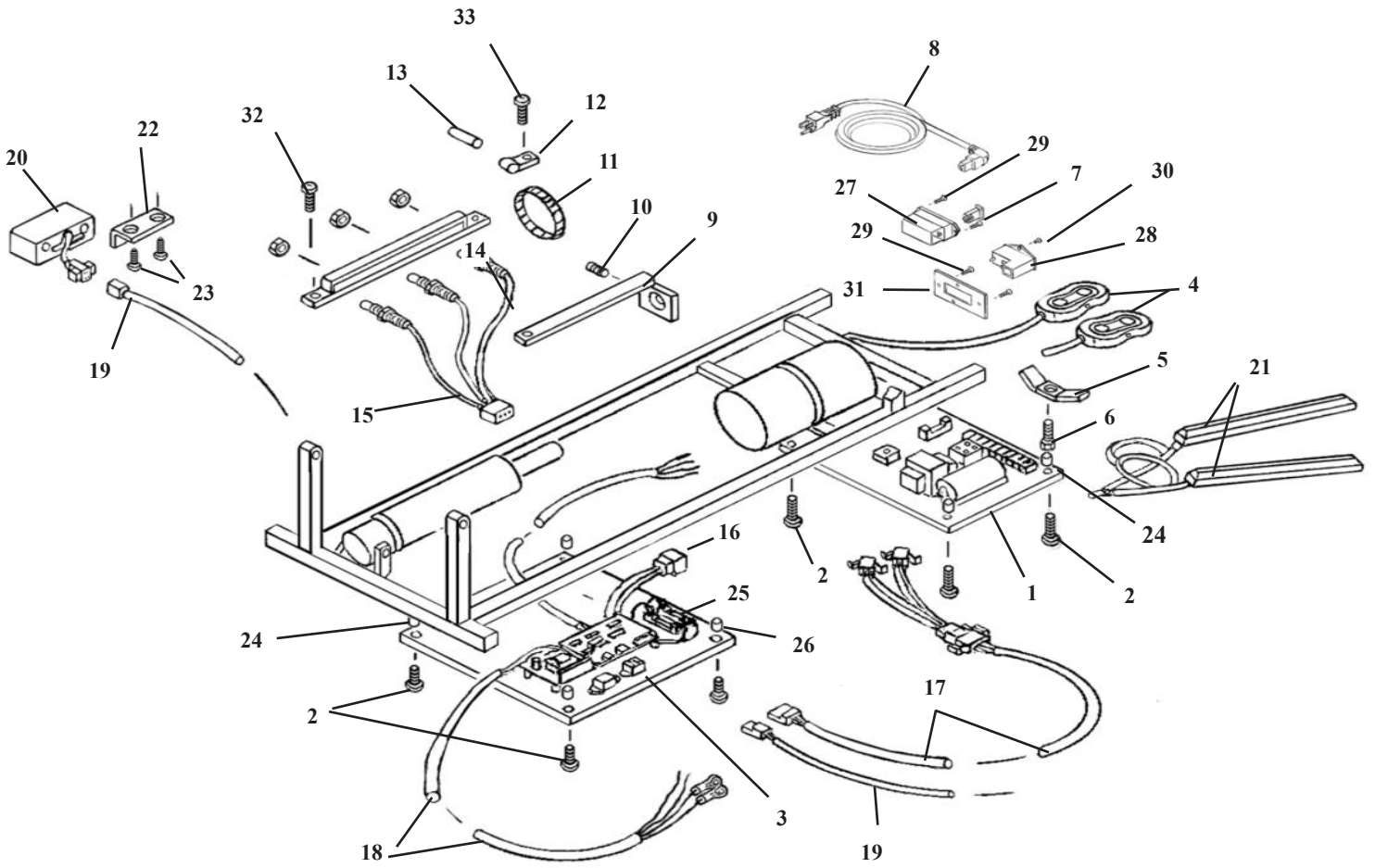

ELECTRICAL ASSEMBLY

EHA & AUTO DROPS

ITEM	PART NO.	DESCRIPTION	QTY.
1	44974	ELECTRICAL UNIT ASS'Y, AUTO DROPS	1
2	22320	MACHINE SCREW, PAN HD, #10-24 UNC X 1	8
3	44977	EHA DRIVER BOARD ASS'Y, w/ AUTO DROPS	1
4	44081	PEDAL ASS'Y, DIRECTIONAL CONTROL	2
5	52073	CLAMP, WIRE HARNESS	5
6	20022	HEX HD. BOLT, ¼-20UNC X 1	1
7A	36377	FUSE HOLDER. 110V	1
7B	36378	FUSE HOLDER 220V	1
8	45192	POWER CORD	1
9	54267	GUIDE COLLAR ASS'Y,	1
10	22120	SET SCREW, ¼-20UNC X ½	1
11	24280	ADJUSTABLE HOSE CLAMP, 2 ½"	1
12	35920	CABLE CLAMP ¼"	1
13	24252	MAGNET	1
14	54259	RAIL ASSEMBLY	1
15	45067	WIRE ASSEMBLY, SENSOR	1
16	45200	CABLE ASSEMBLY, BOARD - SENSOR	1
17	45201	CABLE ASSEMBLY, BOARD – PEDAL	1
18	45193	CABLE ASSEMBLY, AC POWER	1
19	45100	WIRE ASSEMBLY, BOARD – CONRTOL BOX	1
20	44027	EHA CONTROL BOX	1
21	44096	TAPE SWITCH ASS'Y (PAIR)	1
22	54200	SUPPORT BRACKET	1
23	22461	PAN HD. SCREW, #10 X 5/8	2
24	50720	SPACER, 3/8 ID X 1/2 OD	8
25	36325	FUSE, .25 AMP	1
26	36360	FUSE, 6 AMP	1
27	44217	POWER ENTRY, 110 & 220 V	1
28	37186	POWER ENTRY, 100 V	1
29	21980	FLAT HEAD SCREW, #6-32 UNC X 1/2	2
30	21972	FLAT HEAD SCREW, #6-32 UNC X 1/4	2
31	58618	ADAPTER PLATE, 1/8 X 2 X 3 9/16 (110V ONLY)	1
32	21985	PAN HD. MACHINE SCREW, #8-32 UNC X 3/4	1
33	22078	PAN HD. MACHINE SCREW #8-32 UNC X 1/4	1

STRAIGHT DROP HEAD ASSEMBLY

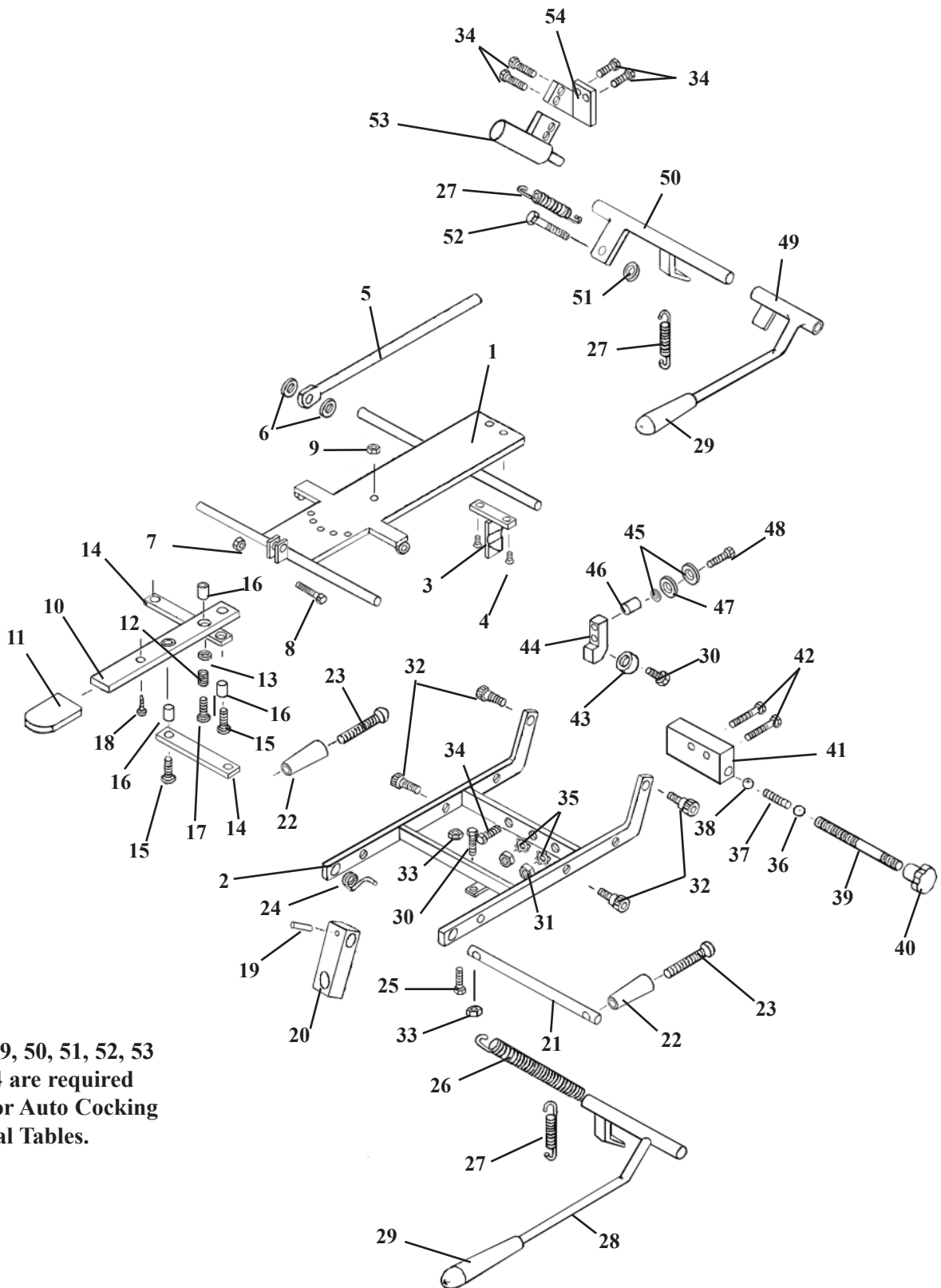

Items 49, 50, 51, 52, 53
and 54 are required
only for Auto Cocking
Cervical Tables.

STRAIGHT DROP HEAD ASSEMBLY

ITEM	PART NO.	DESCRIPTION	QTY.
1	56011	FASTENER PLATE ASS'Y, '89 STRAIGHT DROP HD	1
2	57201	OUTSIDE DROP FRAME ASS'Y, '89 FM HEAD	1
3	55850	TEE WEDGE ASSEMBLY	1
4	22017	SCREW, MACHINE, FLAT HEAD, ¼ - 20 UNC X ½	2
5	55929	CENTER ROD ASSEMBLY	1
6	21616	WASHER, PLASTIC, ¼ ID X ¾ OD	2
7	21020	NUT, HEX, ¼ - 28 UNF	1
8	20115	BOLT, HEX HEAD, ¼ - 28 UNF X ¾	1
9	21450	NUT, HEX, # 10 - 24 UNC	1
10	57221	ADJUSTMENT ARM, 1/8 X 7/8 X 8	1
11	24236	GUARD, TEE HANDLE	1
12	30722	SPRING, COMPRESSION, 0.235 ID X 5/16 OD X ½	1
13	21610	WASHER, PLASTIC, 0.26 ID X ½ OD	2
14	57175	LINKAGE BAR, 1/8 X ½ X 3 13/16	2
15	21995	SCREW, MACHINE, PAN HEAD, # 10 - 24 UNC X ½	2
16	22860	BUSHING, 0.465 ID X 9/16 OD X 19/32	3
17	22003	SCREW, MACHINE, PAN HEAD, # 10 - 24 UNC X ¾	1
18	22300	SCREW, MACHINE, # 8 - 32 UNC X ¼	1
19	22660	ROLL PIN, 1/8 X 5/8	1
20	54107	BLOCK, ADJUSTING, '89 HEAD, 5/8 X 1 X 2 15/16	1
21	57205	ROD, TILT HANDLE, 3/8 RD X 5 ½	1
22	24020	HANDLE	2
23	22050	SCREW, MACHINE, RD HEAD, ¼ - 20 - UNC X 2 ½	2
24	30871	SPRING, TORSION	1
25	20024	BOLT, SOCKET HEAD, ¼ - 20 UNC X 1 ¼	1
26	30785	SPRING, TENSION (HYLO TABLES)	1
27	30725	SPRING, EXTENSION, ¼ ID X 5/16 X 1	1
28	56067	COCKING HANDLE ASS'Y, F/M '89 HEAD	1
29	24010	HANDLE GRIP	1
30	20020	BOLT, HEX HEAD, ¼ - 20 UNC X 1 ¼	2
31	21112	NUT, HEX, 5/16 X 18 UNC	2
32	20197	BOLT, SOCKET HEAD, 5/16 - 18 UNC, SHOULDER, 3/8 X 3/8	4
33	21012	NUT, JAM, ¼ - 20 UNC2	2
34	20007	BOLT, HEX HEAD, ¼ - 20 UNC X 5/8	6
35	21755	WASHER, STAR, 5/16 ID	2
36	22701	BALL, STEEL, ¼ RD	1
37	30721	SPRING, COMPRESSION, 0.175 ID X 23/64 OD X 1 1/8	1
38	22700	BALL, BEARING, 3/8 RD	1
39	57184	STUD, TENSION ADJUSTMENT, 5/16 RD X 2 ¼	1
40	24150	KNOB, TENSION ADJUSTMENT	1
41	55849	BLOCK, DROP, 1 X 1 7/16 X 2 3/32	1
42	20235	BOLT, HEX HEAD, 5/16 - 18 UNC X 1 ¾	2
43	22805	BALL, BEARING, ¼ ID	1
44	57102	BLOCK, BACKER BEARING, STRAIGHT DROP, ¾ X 9/16 X 1 ¼	1
45	21620	WASHER, FLAT, ¼ ID X 9/16 OD X 3/16	2
46	50720	SPACER, 3/8 ID X ½ OD X ½	1
47	21710	WASHER, FLAT, 5/16 ID X 0.688 OD	1
48	20022	BOLT, HEX HEAD, ¼ - 20 UNC X 1	1
49	56069	COCKING HANDLE ASS'Y, F/M '89 HEAD (AUTO DROP)	1
50	57140	COCKING LEVER ASS'Y, F/M '89 HEAD (AUTO DROP)	1
51	21210	NUT, HEX, 3/8 - 16 UNC (AUTO DROP)	1
52	20320	BOLT, HEX HEAD, 3/8 - 16 UNC X ¾ (AUTO DROP)	1
53	625020	COCKING CYLINDER, ¾ RD w/FITTINGS (AUTO DROP)	1
54	57194	BRACKET, CYLINDER ADAPTER (AUTO DROP)	1

FORWARD MOTION HEAD FRAME

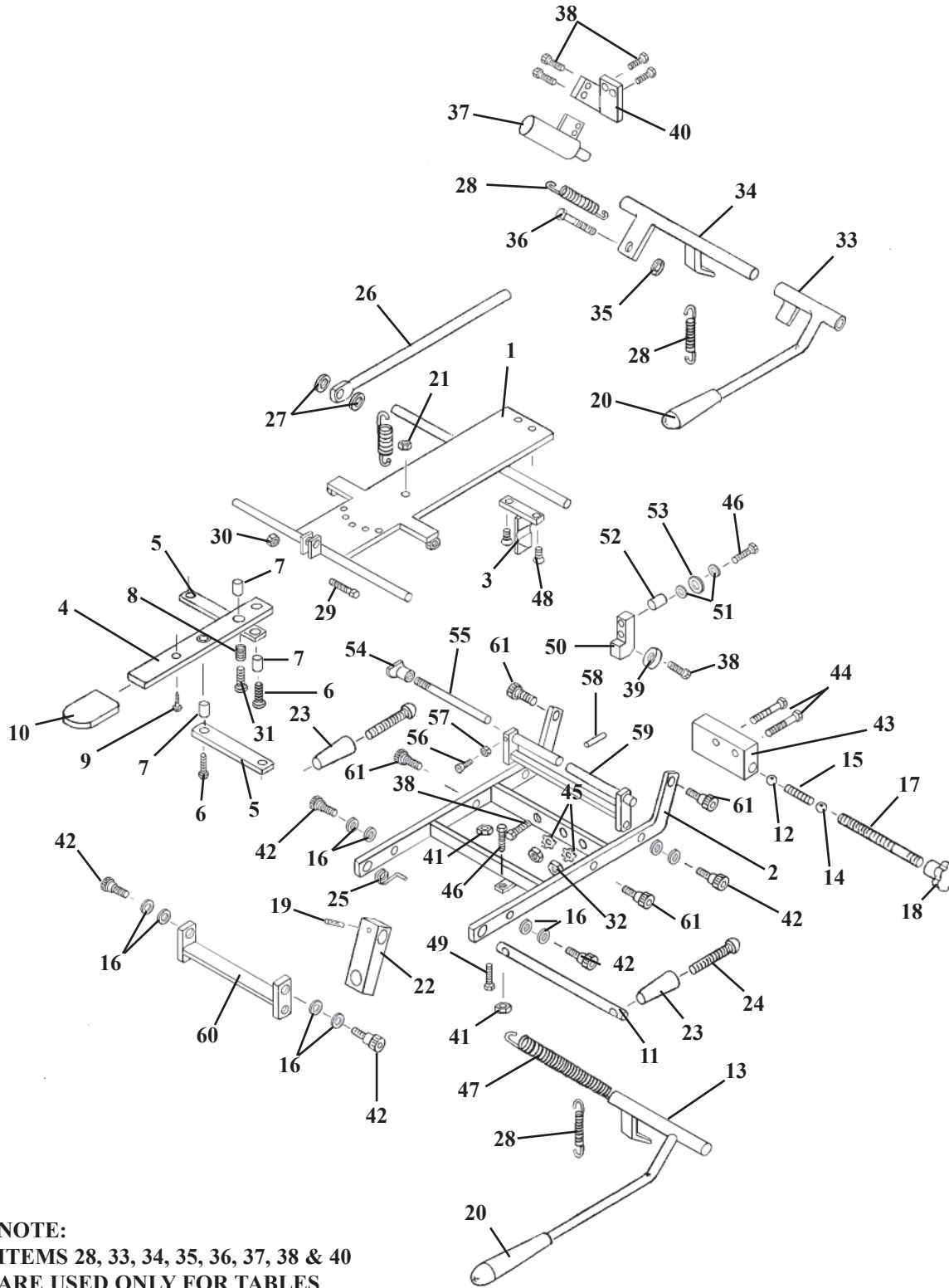

NOTE:
ITEMS 28, 33, 34, 35, 36, 37, 38 & 40
ARE USED ONLY FOR TABLES
WITH
AUTO COCKING CERVICAL.

FORWARD MOTION HEAD FRAME

ITEM	PART NO.	DESCRIPTION	QTY
1	56059	FASTNER FRAME ASS'Y	1
2	57201	OUTSIDE HEAD FRAME ASS'Y	1
3	55850	TEE WEDGE	1
4	57221	ADJUSTMENT ARM, HEAD CUSHION	1
5	57175	LINKAGE BAR, 1/8 X 1/2 X 3 9/16	2
6	21995	PAN HD. MACHINE SCREW, #10-24 NC X 1/2	2
7	22860	BUSHING, 3/16 ID X 1/4 OD	3
8	30722	COMPRESSION SPRING, 1/4 ID X 5/16 OD	1
9	22300	MACHINE SCREW, #8-32 NC X 1/4	1
10	24236	PLASTIC CAP	1
11	57205	SUPPORT ROD, 3/8 RD. X 6 1/16	1
12	22700	BALL, STEEL, 3/8 DIA	1
13	56067	COCKING LEVER ASS'Y	1
14	22701	BALL, BEARING, 1/4 DIA	1
15	30710	COMPRESSION SPRING, 9/64 ID X 1/4 OD	1
16	21760	PLASTIC WASHER, 5/16 ID X 1/2 OD	12
17	57184	TENSION ADJUSTMENT SCREW, 5/16 RD. X 2 3/4	1
18	24150	KNOB, TENSION ADJUSTMENT	1
19	22660	ROLL PIN, 1/8 X 5/8	1
20	24010	COCKING HANDLE	1
21	21450	HEX NUT, #10-24 NC	1
22	54107	ADJUSTING BLOCK, 5/8 X 1.00 X 2 15/16	1
23	24020	ADJUSTMENT HANDLE	2
24	22050	MACHINE SCREW, RD. HD., 1/4-20 NC X 2 1/2	2
25	30871	TORSION SPRING	1
26	55929	CENTER BAR,	1
27	21616	WASHER, FLAT, PLASTIC, 1/4 ID X 3/4 OD	2
28	30725	RETURN SPRING	2
29	20115	HEX.HD BOLT, 1/4-28 NF X 3/4	1
30	21020	NUT, HEX, 1/4-28 NF	1
31	22003	PAN HD. SCREW, #10-24 UNC X 3/4	1
32	21112	HEX.NUT, 5/16-18 UNC	2
33	56069	COCKING HANDLE ASS'Y (AUTO DROPS)	1
34	57140	COCKING LEVER ASS'Y (AUTO DROPS)	1
35	21210	HEX.NUT, 3/8-16 NC (AUTO DROPS)	1
36	20320	HEX.BOLT, 3/8-16 NC X 3/4 (AUTO DROPS)	1
37	625020	COCKING CYLINDER, 3/4 (AUTO DROPS)	1
38	20007	HEX.HD.BOLT, 1/4-20 NC X 5/8 (AUTO DROPS)	6
39	22805	BEARING	1
40	57194	CYL.MT.BRACKET (AUTO DROPS)	1
41	21012	NUT, JAM, 1/4-20 UNC	2
42	20002	SOCKET HD. BOLT, 1/4-20 NC X 1 1/4	6
43	55849	DROP BLOCK	1
44	20235	HEX.HD.BOLT, 5/16-18 NC X 1 3/4	2
45	21755	WASHER, STAR 5/16ID	2
46	20020	HEX.HEAD BOLT, 1/4-20 NC X 1 1/4-GR 5	3
47	30785	TENSION SPRING (HYLO TABLES ONLY)	1
48	22017	FLAT HD. SCREW, 1/4-20UNC X 3/4	2
49	20024	BOLT, SOCKET HEAD, 1/4 - 20 UNC X 1 1/4	1
50	57103	BLOCK	1
51	21620	FLAT WASHER 1/4ID X 9/16OD	2
52	50720	SPACER	1
53	21810	FLAT WASHER 3/8ID X 13/16OD	1
54	24160	LOCK KNOB	1
55	55932	LOCK ROD	1
56	21981	PLASTIC FLAT HD. SCREW, #8-32 NC X 1/2	1
57	21420	HEX.NUT, #8-32NC	1
58	22657	ROLL PIN 1/8 X 3/8	1
59	56060	STABILIZER BRACE ASS'Y	1
60	57144	FRONT ROCKER FRAME ASS'Y	1
61	20197	SOCKET HD. SHOULDER BOLT, 5/16-18 UNC	4

CBP CHEST CUSHION TILT - FRAME ASS'Y

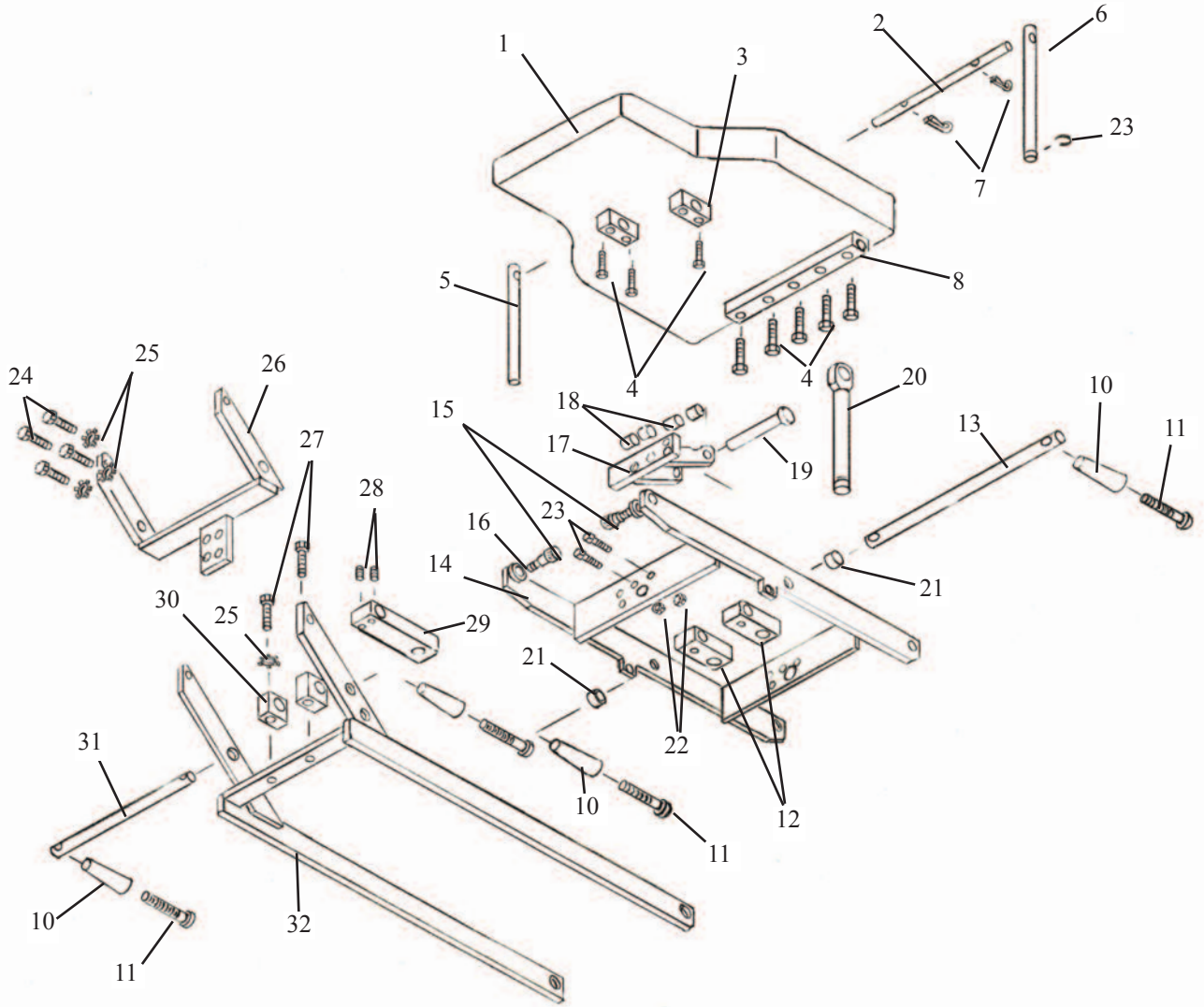

CBP CHEST CUSHION TILT - FRAME ASS'Y

ITEM	PART NO.	DESCRIPTION	QTY.
1	40209	CUSHION ASSEMBLY	1
2	57286	SUPPORT ROD, 3/8 RD. X 6 ½	1
3	57493	SUPPORT BLOCK	2
4	20023	HEX HD. BOLT, ¼-20UNC X 1 ¼	9
5	57492	EYE-ROD, 9/16 RD. X 5 1/8	1
6	57491	EYE-ROD, 9/16 RD. X 5 1/8 (CLIP)	1
7	22639	COTTER PIN, 3/32 X ½	2
8	57489	HINGE BLOCK	1
9	22670	ROLL PIN, 1/8 X ¾	2
10	24020	ADJUSTMENT HANDLE	2
11	22050	RD. HD. MACHINE SCREW, ¼-20UNC X 2 ½	2
12	57737	ADJUSTMENT BLOCK	2
13	57285	SUPPORT ROD, ½ RD. X 12 ½	1
14	57280	CHEST FRAME ASS'Y	1
15	20199	SOCKET HD. SHLD.BOLT, 3/8-16 UNC X 3/8 x ½	2
16	21800	PLASTIC WASHER, 3/8 ID	2
17	57458	SUPPORT BRACKET ASS'Y	1
18	52150	SPACER	4
19	22679	SUPPORT PIN, ½ DIA. X 3 ½	1
20a	57450	EYE-ROD ASS'Y (GALAXY)	1
20b	56410	EYE-ROD ASS'Y (402 FLEXION)	1
21	22915	COLLAR ½"	2
22	21210	HEX. NUT, 3/8-16 UNC	6
23	24286	E-CLIP, 9/16	1
24	20332	HEX. BOLT, 3/8-16 UNC X 1.00	6
25	21820	WASHER, STAR, 3/8ID X 11 1/6	6
26	56316	HANGER BRACKET ASS'Y	1
27	20057	HEX HD. BOLT, 3/8-16UNC X 2 ¼	2
28	22110	SET SCREW, ¼-20UNC X ¼	2
29	54082	DROP BLOCK	1
30	57473	SUPPORT BLOCK	2
31	56235	ROD, ADJUSTMENT, 1/2RD X 12 ½	1
32	56226	CHEST FRAME ASS'Y	1

CBP DROP CHEST ASSEMBLY SPRING BREAKAWAY

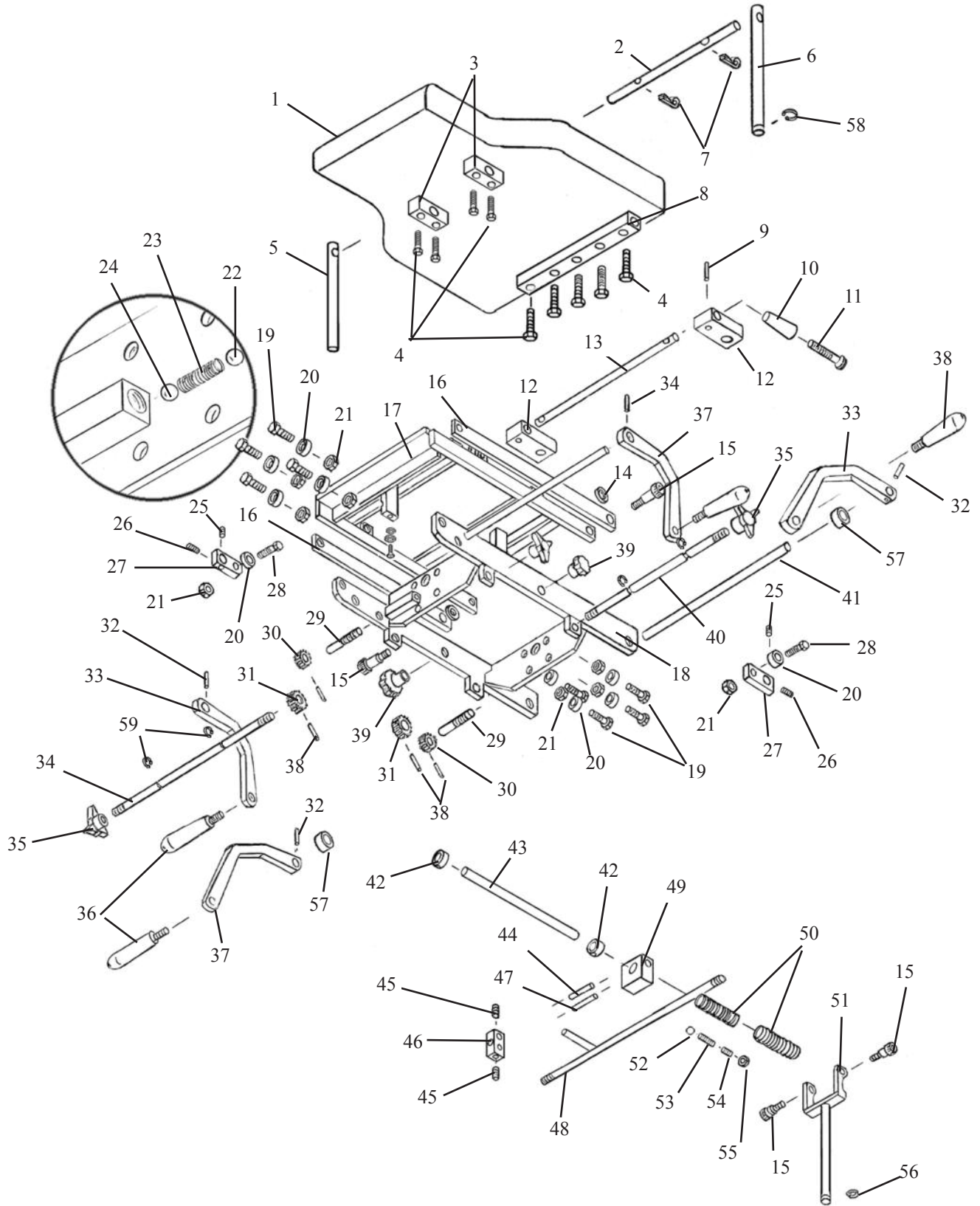

CBP DROP CHEST ASSEMBLY SPRING BREAKAWAY

ITEM	PART NO.	DESCRIPTION	QTY.
1	40209	CUSHION ASSEMBLY	1
2	57286	SUPPORT ROD, 3/8 RD. X 6 1/2	1
3	57493	SUPPORT BLOCK	2
4	20023	HEX HD. BOLT, 1/4-20UNC X 1 1/4	9
5	57492	EYE-ROD, 9/16 RD. X 5 1/8	1
6	57491	EYE-ROD, 9/16 RD. X 5 1/8 (CLIP)	1
7	22639	COTTER PIN, 3/32 X 1/2	2
8	57489	HINGE BLOCK	1
9	22670	ROLL PIN, 1/8 X 3/4	2
10	24020	ADJUSTMENT HANDLE	2
11	22050	RD. HD. MACHINE SCREW, 1/4-20UNC X 2 1/2	2
12	57737	ADJUSTMENT BLOCK	2
13	57285	SUPPORT ROD, 1/2 RD. X 12 1/2	1
14	21800	PLASTIC WASHER, 3/8ID	2
15	20204	SOCKET HD. SHLD. BOLT, 5/16-18 UNC X 3/4	4
16	57490	LINKAGE BAR	2
17	57476	INSIDE T-DROP FRAME ASS'Y	1
18	57475	CHEST FRAME ASS'Y	1
19	20330	HEX, HD. BOLT, 3/8-16UNC X 7/8	8
20	22812	ROLLER BEARING	10
21	21210	HEX. NUT, 3/8-16UNC	10
22	22710	TENSION BALL, 1/2"	2
23	30830	TENSION SPRING	2
24	22700	TENSION BALL 3/8"	2
25	22260	SET SCREW, 5/16-24UNF X 1/4	2
26	22250	SET SCREW, 5/16-24UNF X 1/2	2
27	52730	COCKING ARM	1
28	20350	HEX HD. BOLT, 3/8-16UNC X 1 1/4	2
29	57454	TENSION SCREW, 3/8 RD X 2 1/2	2
30	30311	TENSION GEAR, 3/8ID X 15/16OD	2
31	30312	TENISON GEAR, 3/8ID X 1 1/8OD	2
32	22670	ROLL PIN, 1/8 X 3/4	4
33	57472	COCKING HANDLE BAR (RH)	2
34	57448	TENSION ROD, 3/8RD X 12 3/4	1
35	24180	CONTROL KNOB	2
36	24012	COCKING HANDLE (BLACK)	4
37	57449	COCKING HANDLE BAR (LH)	2
38	22673	ROLL PIN, 1/8 X 1	4
39	24150	CONTROL KNOB	2
40	57447	TENSION ROD, 3/8 X 17 1/2	1
41	57444	COCKING ROD, 1/2 RD X 13	1
42	22940	COLLAR 5/8ID X 23/32OD	2
43	57446	CENTER ROD, 5/8RD X 9	1
44	57344	GUIDE PIN, 1/4RD X 2 1/8	1
45	22160	SET SCREW, 1/4-28UNF X 1/4	2
46	57343	LINKAGE BLOCK	1
47	57345	LOCK PIN, 5/16RDX 3	1
48	57438	SLIDE ROD ASS'Y	1
49	51090	CENTER BLOCK	1
50	30793	COMPRESSION SPRING	2
51	56190	FORK ASS'Y	1
52	22702	BEARING BALL 3/16	1
53	30715	COMPRESSION SPRING	1
54	22120	SET SCREW, 1/4-20UNC X 1/2	1
55	21012	HEX. NUT 1/4-20UNC	1
56	24286	E-CLIP, 3/8	1
57	54088	SET COLLAR, 1/2 ID X 1.00 OD	2

DROP CHEST ASSEMBLY

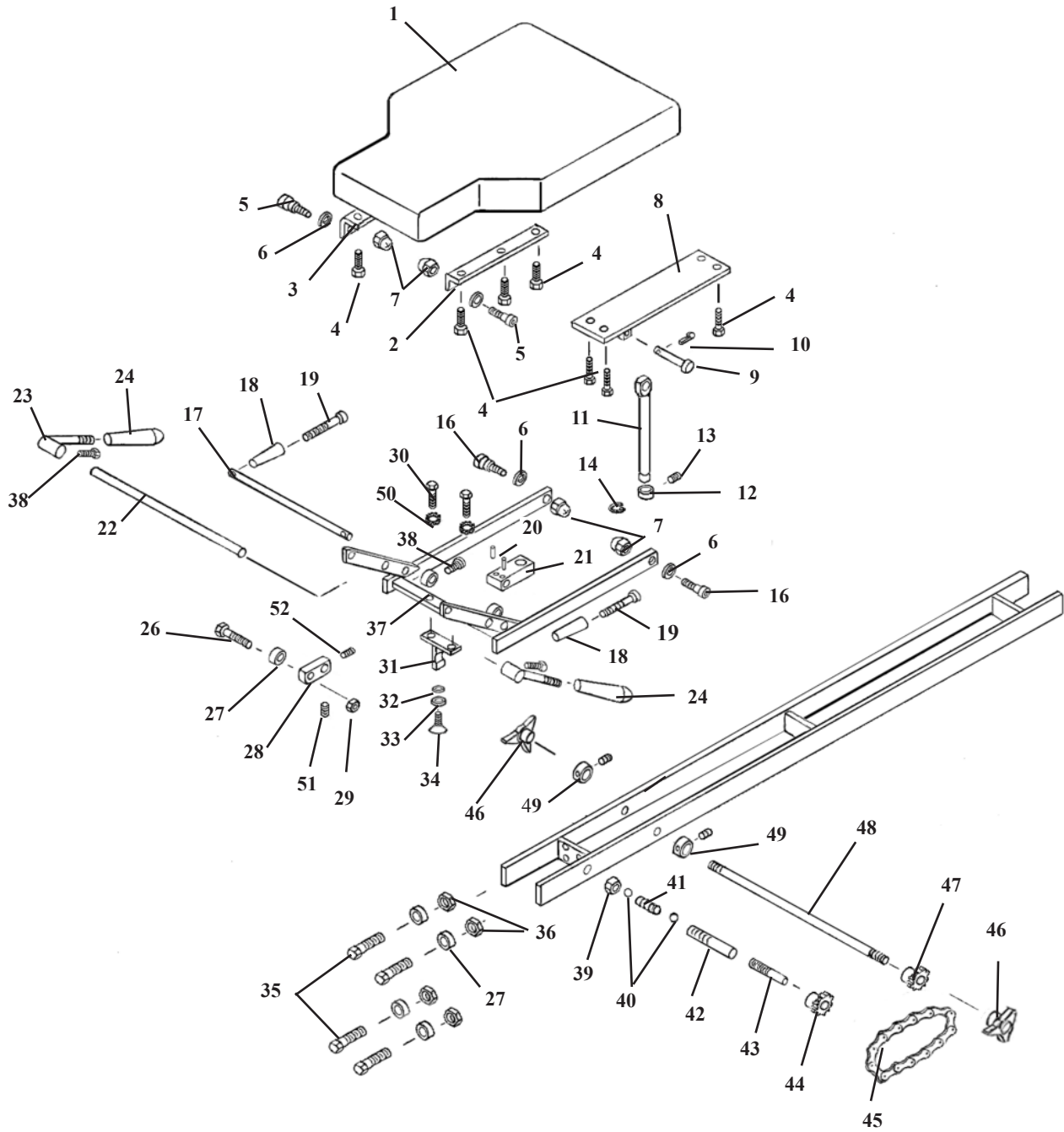

DROP CHEST ASSEMBLY

ITEM	PART NO.	DESCRIPTION	QTY.
1	40210	CHEST CUSHION	1
2	51010	BRACE RAIL (LH)	1
3	51030	BRACE RAIL (RH)	1
4	20022	HEX. HD. BOLT, 1/4-20 UNC x 1.00	8
5	20199	SOCKET HD. BOLT, 5/16-18 UNC SHLD. 3/8 X 1/2	4
6	21800	PLASTIC FLAT WASHER, 3/8 ID X 5/8 OD	2
7	21114	CAP NUT, 5/16-18 UNC	4
8	55149	BRACKET ASSEMBLY	1
9	22677	CYLINDER PIN, 1/2 X 2 5/8	1
10	22640	COTTER PIN, 3/32 X 1	1
11	57450	EYE-ROD, 9/16 RD X 6 9/16	1
12	22935	SET COLLAR, 9/16	2
13	22110	SET SCREW, 1/4-20 UNC X 1/4	2
14	24286	SNAP RING, 9/16	1
15	56226	CHEST FRAME ASSEMBLY	1
16	20204	SOCKET HD. BOLT, 5/16-18 UNC SHLD. 3/8 X 3/4	2
17	56235	ROD, ADJUSTMENT, 1/2 OD X 12 1/2	1
18	24020	ADJSUTMENT HANDLE	2
19	22050	SCREW, RD. HD. MACHINE, 1/4-20 UNC X 2 1/2	2
20	22660	ROLL PIN, 1/8RD. X 5/8	1
21	54082	ADJUSTMENT BLOCK	1
22	52510	ROD, COCKING, 1/2 RD X 20	1
23	57118	COCKING HANDLE ASSEMBLY	2
24	24010	HANDLE GRIP	2
25	22235	SCREW, SQ. HD. 5/16-18 UNC X 3/4	2
26	20332	BOLT, HEX. HD. 3/8-16 UNC X 1	1
27	22812	ROLLER BEARING, 3/8 ID	5
28	52730	COCKING ARM	2
29	21210	HEX. NUT, 3/8-16 UNC	1
30	20320	BOLT, HEX HD. 3/8-16 UNC X 3/4	2
31	56222	T-WEDGE	1
32	57719	BUSHING, 3/8 ID X 1/2 OD X 0.35	1
33	21640	WASHER, 9/32 ID X 1 OD	1
34	22020	SCREW, MACHINE, TRUSS HD. 1/4-20 UNC X 1	1
35	20332	BOLT, HEX. HD. 3/8-16 UNC X 1	4
36	21211	NUT, JAM, 3/8-16UNC	4
37	22913	COLLAR, 1/2 ID	2
38	20024	BOLT, SOCKET HD. 1/4-20 UNC X 1 1/4	2
39	21250	NUT, HEX. 3/4-16UNC	2
40	22710	STEEL BALL 1/2 DIA.	2
41	30830	SPRING TENSION, 1/4 ID X 1/2 OD X 2	1
42	56234	COCKING TUBE	1
43	56243	STUD, TENSION, 3/8- 16 UNC X 2 1/2	1
45	24210	CHAIN, #25 X 9 1/2	1
46	24180	TENSION KNOB	2
47	52740	SPROCKET #9	1
48	52510	ROD, TENSION, 3/8 RD. X 18	1
49	22912	COLLAR, 3/8 ID	2
50	21820	WASHER, STAR, 3/8 ID X 11/16 OD	2
51	22260	SET SCREW, 5/16-24 UNF X 1/4	1
52	22250	SET SCREW, 5/16-24 UNF X 1/2	1

DROP PELVIC ASSEMBLY

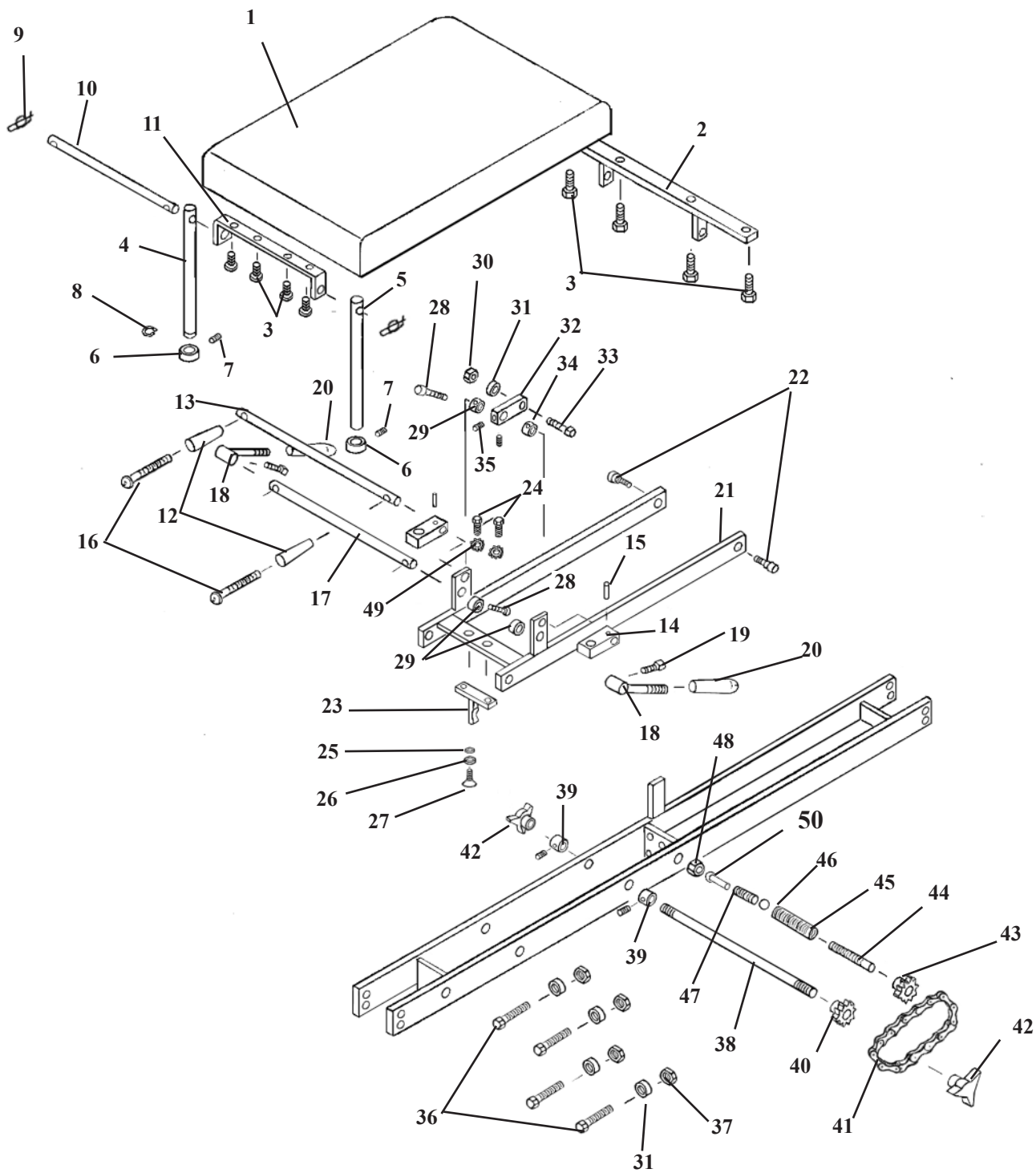

DROP PELVIC ASSEMBLY

ITEM	PART NO.	DESCRIPTION	QTY.
1	40284	PELVIC CUSHION	1
2	54213	HINGE ASSEMBLY	1
3	20022	BOLT, HEX HEAD, 1/4 - 20 NC X 1 1/4	8
4	57735	EYE-ROD, PELVIC, 9/16 RD X 7 13/16	1
5	57738	EYE-ROD, PELVIC, 9/16 RD X 7 13/16 - PLAIN	1
6	22935	COLLAR, SET, 9/16"	2
7	22110	SET SCREW, 1/4 - 20 NC X 1/4	2
8	24286	SNAP RING, 9/16"	1
9	22635	RUE CLIP, 3/8	2
10	57745	ROD, STABILIZER	1
11	57720	FRONT BRACKET ASSEMBLY	1
12	24020	HANDLE, ADJUSTMENT	2
13	57739	ROD, ADJUSTMENT	1
14	57737	BLOCK, ADJUSTMENT	2
15	22660	ROLL PIN, 1/8 X 5/8	2
16	22050	SCREW, MACHINE, ROUND HD, 1/4 - 20 NC X 2 1/2	2
17	55136	ROD, COCKING, 1/2 RD X 20"	1
18	57118	COCKING HANDLE ASSEMBLY	2
19	22235	SCREW, SQUARE HEAD, SET, 5/16 - 18 NC X 3/4	2
20	24010	HANDLE GRIP	2
21	56218	UNION FRAME ASSEMBLY	1
22	20199	BOLT, SOCKET HD, 5/16 - 18 NC X 1/2, SHOU 3/8 X 1/2	2
23	56222	T-WEDGE ASS'Y	1
24	20320	BOLT, HEX HEAD, 3/8 - 16 NC X 3/4	2
25	57719	BUSHING, 0.38 ID X 1/2 OD X 0.35	1
26	21640	WASHER, 9/32 ID X 1 OD - FENDER	1
27	22020	SCREW, MACHINE, TRUSS HD, 1/4 - 20 NC X 1	1
28	20024	BOLT, SOCKET HEAD, 1/4 - 20 NC X 1 1/4	2
29	22913	COLLAR, 1/2 ID	2
30	21210	NUT, HEX, 3/8 - 16 NC	1
31	22812	ROLLER BEARING, 3/8 ID	5
32	52730	COCKING ARM	2
33	20332	BOLT, HEX HEAD, 3/8 - 16 NC X 1	1
34	22260	SET SCREW, 5/16 - 24 NF X 1/4	1
35	22250	SET SCREW, 5/16 - 24 NF X 1/2	1
36	20332	BOLT, HEX HEAD, 3/8 - 16 NC X 1	4
37	21211	NUT, JAM, 3/8 - 16 NC	4
38	52510	ROD, TENSION, 3/8 RD X 18	2
39	22912	COLLAR, 3/8 ID	2
40	52742	SPROCKET, # 11	1
41	24210	CHAIN, # 25, 9 1/2"	1
42	24180	KNOB, TENSION	2
43	52740	SPROCKET, # 9	1
44	52690	STUD, TENSION, 3/8 THD X 2 1/4	1
45	56234	TUBE, COCKING	1
46	22710	STEEL BALL, 1/2 DIA	2
47	30830	SPRING, TENSION, 1/4 ID X 1/2 OD X 2	1
48	21250	NUT, HEX, 3/4 - 16 NC	2
49	21820	WASHER, STAR, 3/8 ID X 11/16 OD	2
50	57421	TENSION PLUNGER, 1/2 RD X 1 3/16	1

LLOYD TABLE COMPANY

PRODUCTS & ACCESSORIES



LLOYD  **TABLE
COMPANY**

102-122 W. Main Street • Lisbon, Iowa 52253-0899 • Phone 319-455-2110
Call Toll Free 1-800-553-7297 FAX: 319-455-2166

www.lloydtable.com

We support chiropractic research!
FCER
VANGUARD CLUB DONOR